

# INSTALLATION MANUAL

FOR ROTAX<sup>®</sup> ENGINE TYPE 912 i SERIES



## **WARNING**

Before starting with engine installation, please read the Installation Manual completely as it contains important safety relevant information.

This Installation Manual for the ROTAX<sup>®</sup> aircraft engines should only be used as a general installation guide for the installation of ROTAX<sup>®</sup> engines into airframes. It should not be used as instruction for the installation of a ROTAX<sup>®</sup> aircraft engine in a specific type of airframe or airplane. BRP-Powertrain GmbH & Co. KG does not assume any warranty or liability in this context.

In no event shall the Installation Manual be used without following the specific instructions and/or requirements of the manufacture of an airframe or airplane ("Manufacturer"). For verification and/or for release of the engine installation, the respective Manufacturer must be contacted. Any modifications or adaptations to the airframe or airplane shall be carried out and/or be verified and released by the Manufacturer only.

Improper use of the Installation Manual and/or non compliance with the installation requirements of the Manufacturers can cause personal injury or property damage. BRP-Powertrain GmbH & Co. KG disclaims any liability for any and all damage and/or injuries (including death) resulting from the improper use of Installation Manual and non compliance with the installation requirements of the Manufacturer.

These technical data and the information embodied therein are the property of BRP-Powertrain GmbH & CO. KG, Austria, acc, BGBl 1984 no. 448, and shall not, without prior written permission of BRP-Powertrain GmbH & Co. KG, be disclosed in whole or in part to third parties. This legend shall be included on any reproduction of these data, in whole or in part. The Manual must remain with the engine/aircraft in case of sale.

Copyright 2014 © - all rights reserved.

ROTAX<sup>®</sup> is a trade mark of BRP-Powertrain GmbH & Co. KG. In the following document the short form of BRP-Powertrain GmbH & Co. KG = BRP-Powertrain is used.

Other product names in this documentation are used purely for ease of identification and may be trademarks of the respective company or owner.

Approval of translation has been done to best knowledge and judgement - in any case the original text in german language is authoritative.

**BRP-Powertrain**  
INSTALLATION MANUAL

**Chapter: INTRO**  
**GENERAL NOTE**

**Foreword**

Before starting with the engine installation, read this Installation Manual carefully. The Manual will provide you with basic information on correct engine installation, a requirement for safe engine operation.

If any passages of this Manual are not clearly understood or if you have any questions, please contact an authorized distributor- or Service Center for ROTAX aircraft engines.

BRP-Powertrain GmbH & Co KG (hereinafter "BRP-Powertrain") wishes you much pleasure and satisfaction flying your aircraft powered by this ROTAX aircraft engine.

**Chapter structure**

The structure of the Manual follows whenever it is possible the structure of the ATA (Air Transport Association) standards. The aim is the compatibility with the aircraft manufacturer's documentation, which means they must then adapt the documentation to their standard.

The Installation Manual is subdivided into the following chapters:

Subject	Chapter
Introduction	<a href="#">Chapter INTRO</a>
List of effective pages	<a href="#">Chapter LEP</a>
Table of amendments	<a href="#">Chapter TOA</a>
General note	<a href="#">Chapter 00-00-00</a>
Storage & Installation	<a href="#">Chapter 10-10-00</a>
Electric system	<a href="#">Chapter 24-00-00</a>
Propeller drive	<a href="#">Chapter 61-00-00</a>
Engine	<a href="#">Chapter 72-00-00</a>
Fuel system	<a href="#">Chapter 73-00-00</a>
Ignition system	<a href="#">Chapter 74-00-00</a>
Cooling system	<a href="#">Chapter 75-00-00</a>
Engine management	<a href="#">Chapter 76-00-00</a>
Exhaust system	<a href="#">Chapter 78-00-00</a>
Lubrication system	<a href="#">Chapter 79-00-00</a>
Electric starter	<a href="#">Chapter 80-00-00</a>

d05150.fm

**BRP-Powertrain**  
INSTALLATION MANUAL

NOTES

*d05150.fm*

**BRP-Powertrain**  
INSTALLATION MANUAL

**Chapter: LEP**  
**LIST OF EFFECTIVE PAGES**

chapter	page	date
	Title page	
INTRO	1	01 01 2012
	2	01 01 2012
LEP	1	01 01 2014
	2	01 01 2014
	3	01 01 2014
	4	01 01 2012
TOA	1	01 01 2014
	2	01 01 2014
	3	01 01 2014
	4	01 01 2012
00-00-00	1	01 01 2012
	2	01 01 2012
	3	01 01 2012
	4	07 01 2012
	5	01 01 2014
	6	01 01 2012
	7	01 01 2012
	8	01 01 2014
	9	01 01 2014
	10	01 01 2012
	11	01 01 2014
	12	01 01 2014
	13	01 01 2012
	14	01 01 2012
	15	01 01 2012
	16	01 01 2012
	17	01 01 2012
	18	01 01 2012
10-10-00	1	01 01 2012
	2	01 01 2012
	3	01 01 2012
	4	01 01 2012
	5	01 01 2012
	6	01 01 2012
	7	01 01 2012
	8	01 01 2012
	9	01 01 2012
	10	01 01 2012
	11	01 01 2012
	12	01 01 2012

chapter	page	date
24-00-00	1	01 01 2014
	2	01 01 2012
	3	01 01 2014
	4	01 01 2014
	5	01 01 2014
	6	01 01 2014
	7	01 01 2014
	8	01 01 2014
	9	01 01 2014
	10	01 01 2014
	11	01 01 2014
	12	01 01 2014
	13	01 01 2014
	14	01 01 2014
	15	01 01 2014
	16	01 01 2014
	17	01 01 2014
	18	01 01 2014
	19	01 01 2014
	20	01 01 2014
	21	01 01 2014
	22	01 01 2014
	23	01 01 2014
	24	01 01 2014
	25	01 01 2014
	26	01 01 2014
	27	01 01 2014
	28	01 01 2014
	29	01 01 2014
	30	01 01 2014
	31	01 01 2014
	32	01 01 2014
	33	01 01 2014
	34	01 01 2014
	35	01 01 2014
	36	01 01 2014
61-00-00	1	01 01 2012
	2	01 01 2012
	3	01 01 2012
	4	01 01 2014
	5	01 01 2012
	6	01 01 2012

d05778.fm

**BRP-Powertrain**  
INSTALLATION MANUAL

chapter	page	date	chapter	page	date	
72-00-00	1	01 01 2012	75-00-00	15	01 01 2012	
	2	01 01 2012		16	01 01 2012	
	3	01 01 2012		17	01 01 2014	
	4	01 01 2012		18	01 01 2014	
	5	01 01 2012		19	01 01 2014	
	6	01 01 2012		20	01 01 2014	
	7	01 01 2014		21	01 01 2014	
	8	01 01 2014		22	01 01 2014	
	9	01 01 2014		76-00-00	1	01 01 2014
	10	01 01 2012			2	01 01 2014
	11	07 01 2012			3	01 01 2014
	12	07 01 2012			4	01 01 2014
73-00-00	1	01 01 2014	5		01 01 2014	
	2	01 01 2014	6		01 01 2014	
	3	01 01 2014	7		01 01 2014	
	4	01 01 2014	8		01 01 2014	
	5	01 01 2014	9		01 01 2014	
	6	01 01 2014	10		01 01 2014	
	7	01 01 2014	11		01 01 2014	
	8	01 01 2014	12		01 01 2014	
	9	01 01 2014	13	01 01 2014		
	10	01 01 2014	14	01 01 2014		
	11	01 01 2014	15	01 01 2014		
	12	01 01 2014	16	01 01 2014		
	13	01 01 2014	78-00-00	1	01 01 2014	
	14	01 01 2014		2	01 01 2014	
	15	01 01 2014		3	01 01 2012	
	16	01 01 2014		4	01 01 2012	
74-00-00	1	07 01 2012		5	01 01 2014	
	2	01 01 2012		6	01 01 2014	
	3	07 01 2012		7	01 01 2014	
	4	01 01 2012		8	01 01 2012	
75-00-00	1	01 01 2012		9	01 01 2014	
	2	01 01 2012		10	01 01 2014	
	3	01 01 2012		11	01 01 2014	
	4	01 01 2012		12	01 01 2014	
	5	01 01 2012		13	01 01 2014	
	6	01 01 2012		14	01 01 2014	
	7	01 01 2012	79-00-00	1	01 01 2012	
	8	01 01 2012		2	01 01 2012	
	9	01 01 2012		3	01 01 2012	
	10	01 01 2012		4	01 01 2012	
	11	01 01 2012		5	07 01 2012	
	12	01 01 2012		6	01 01 2012	
	13	01 01 2012		7	01 01 2012	
	14	01 01 2012		8	01 01 2012	

d05778.fm

**BRP-Powertrain**  
INSTALLATION MANUAL

chapter	page	date
79-00-00	9	01 01 2012
	10	01 01 2012
	11	01 01 2012
	12	01 01 2012
	13	01 01 2012
	14	01 01 2012
	15	01 01 2012
	16	01 01 2012
	17	01 01 2012
	18	01 01 2012
	19	01 01 2012
	20	01 01 2012
	21	01 01 2012
	22	01 01 2012
	23	01 01 2012
	24	01 01 2012
	25	01 01 2012
	26	01 01 2012
	27	01 01 2012
	28	01 01 2012
29	01 01 2012	
30	01 01 2012	
80-00-00	1	01 01 2012
	2	01 01 2012
	3	01 01 2012
	4	01 01 2012
	5	01 01 2012
	6	01 01 2012
	Rear page	

d05778.fm

**BRP-Powertrain**  
INSTALLATION MANUAL

NOTES



**BRP-Powertrain**  
INSTALLATION MANUAL

**Chapter: TOA**  
**TABLE OF AMENDMENTS**

**Approval\***

The technical content of this document is approved  
under the authority DOA ref. EASA.21.J.048

no.	chapter	page	date of change	remark for approval	date of approval from authorities	date of inclusion	signature
0	INTRO	all	01 01 2012				
0	LEP	all	01 01 2012				
0	TOA	all	01 01 2012				
0	00-00-00	all	01 01 2012				
0	10-10-00	all	01 01 2012				
0	24-00-00	all	01 01 2012				
0	61-00-00	all	01 01 2012				
0	72-00-00	all	01 01 2012				
0	73-00-00	all	01 01 2012				
0	74-00-00	all	01 01 2012				
0	75-00-00	all	01 01 2012				
0	76-00-00	all	01 01 2012				
0	78-00-00	all	01 01 2012				
0	79-00-00	all	01 01 2012				
0	80-00-00	all	01 01 2012				
1	LEP	1, 2	07 01 2012	DOA*			
1	TOA	1, 3	07 01 2012	DOA*			
1	00-00-00	4, 5	07 01 2012	DOA*			
1	24-00-00	1,4,5,9,22,24-26	07 01 2012	DOA*			
1	72-00-00	1,11,12	07 01 2012	DOA*			
1	73-00-00	1,3,5,6	07 01 2012	DOA*			
1	74-00-00	1,3	07 01 2012	DOA*			
1	76-00-00	1,3,7,9,12	07 01 2012	DOA*			
1	78-00-00	5,7	07 01 2012	DOA*			
1	79-00-00	5	07 01 2012	DOA*			
2	LEP	1,2,3	01 01 2014	DOA*			
2	TOA	1,2,3	01 01 2014	DOA*			
2	00-00-00	8,9,11,12	01 01 2014	DOA*			
2	24-00-00	1,3-36	01 01 2014	DOA*			
2	61-00-00	4	01 01 2014	DOA*			
2	72-00-00	7,8,9	01 01 2014	DOA*			

d05779.fm

**BRP-Powertrain**  
INSTALLATION MANUAL

no.	chapter	page	date of change	remark for approval	date of approval from authorities	date of inclusion	signature
2	73-00-00	1-16	01 01 2014	DOA*			
2	75-00-00	17-22	01 01 2014	DOA*			
2	76-00-00	1-16	01 01 2014	DOA*			
2	78-00-00	1,5,6,7,9-14	01 01 2014	DOA*			

**BRP-Powertrain**  
INSTALLATION MANUAL

**Chapter: TOA**  
**SUMMARY OF AMENDMENTS**

**Content**                      Summary of the relevant amendments in this context, but without requirement on completeness.

Current No.	chapter	page	date of change	Comment
1	00-00-00	5	2012 07 01	Chap. 2.1 Standard version: Fuel pump assy.
1	24-00-00	4,9, 23	2012 07 01	Chap. 1.1 Electromagnetic compatibility: Change of text
1	73-00-00	1,3,5,6	2012 07 01	Chap. 1.5+1.7.2 Coarse+fine filter: mesh size
1	76-00-00	9, 12	2012 07 01	Chap. 3 Internal generator: Change of text Chap. 5.3 Wiring diagram: New graphics
1	78-00-00	5,7	2012 07 01	Chap. 2 Exhaust system requirements: Text Chap. 3 Positioning the sensor: Text Chap. 3.1 Pin assignment for maintenance tool: Text Chap. 4.1 Pin assignment for display: New graphics
1	79-00-00	5	2012 07 01	Chap. 1.3 Measurement of crankcase pressure: Text
2	00-00-00	11,12	2014 01 01	Chap.4 New Symbol Tip
2	24-00-00	5 6-14, 15-36	2014 01 01	Chap. 4.1 Safety information: Text Chap. 1.2.1 Technical Data: Text New Text position and change of text Change of text in chapter
2	61-00-00	4	2014-01-01	Chap. 1.1: Technical data: New graphic
2	72-00-00	7,8	2014 01 01	Chap. 2.1 Weight: Text, Chap. 2.2 Installation dimensions: Text
2	73-00-00	1-16	2014 01 01	Overview fuel system: New graphic
2	75-00-00	17-22	2014 01 01	Chap. 1 Requirements of the fuel system: Text Chap.4 General notes on the cooling system: Text, New graphic, New text position
2	76-00-00	1,3,6, 7-16	2014 01 01	New text, Chap. 1.4 Installation position of the ECU: Text Chap. 2.2 Connections: Text, Chap. 4 Display:Text New graphic
2	78-00-00	5,6 7,9-14	2014 01 01	Chap. 2 Exhaust requirements: Text Chap. 2.2 If a genuine ROTAX exhaust is not used: Text Chap. 3 Installation of the exhaust system: Text deleted Chap. 4 Change of text Chap 4.1 Exhaust system assy.: New graphic

d05779.fm

**BRP-Powertrain**  
INSTALLATION MANUAL

NOTES

**BRP-Powertrain**  
INSTALLATION MANUAL

**Chapter: 00-00-00**  
**GENERAL NOTE**

**Introduction** This section describes the installation of engine type ROTAX 912 i Series.

**NOTE:** ROTAX 912 i Series includes 912 iSc and 912 iS.

**Table of contents** This chapter of the Installation Manual contains general and safety information concerning the operation and maintenance of the aircraft engine.

Subject	Page
General note	<a href="#">Page 3</a>
Type description Standard version	<a href="#">Page 4</a> <a href="#">Page 5</a>
Abbreviations and terms used in this Manual Conversion table	<a href="#">Page 7</a> <a href="#">Page 10</a>
Safety notice Safety information Instruction Technical documentation	<a href="#">Page 11</a> <a href="#">Page 12</a> <a href="#">Page 14</a> <a href="#">Page 15</a>

d05780.fm

**BRP-Powertrain**  
INSTALLATION MANUAL

NOTES

d05780.fm

# BRP-Powertrain

## INSTALLATION MANUAL

### 1) General note

<b>Purpose</b>	The purpose of this Installation Manual is to acquaint maintenance service staff (iRMT) approved by the local aviation authorities with some basic installation and safety information for service work.
<b>Documentation</b>	For more detailed information regarding, installation, maintenance, safety- or flight operation, consult the documentation provided by the aircraft manufacturer and/or dealer. For additional information on engines, maintenance or parts, you can also contact your nearest authorized ROTAX-aircraft engine distributor.
<b>ROTAX Distributors</b>	For ROTAX Authorized Distributors for Aircraft Engines see latest Operators Manual or on the Internet at the official Website <a href="http://www.FLYROTAX.com">www.FLYROTAX.com</a> .
<b>Engine serial number</b>	When making inquiries or ordering parts, always indicate the engine serial number, as the manufacturer makes modifications to the engine for product improvement. The engine serial number (1) is on the top of the crankcase, behind of the propeller gearbox.

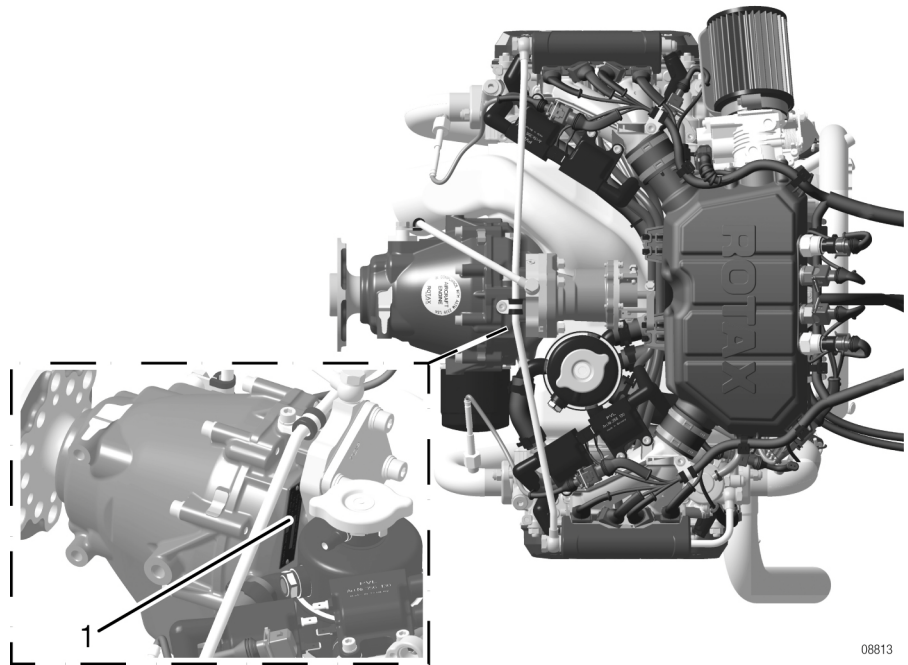

Fig. 1

**BRP-Powertrain**  
INSTALLATION MANUAL

**2) Type description**

e.g. 912 iSc 3

The type description is made up the following:

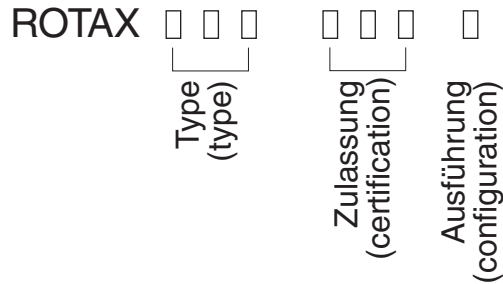

**Designation**

Designation	Description
<b>Type</b>	<b>912</b> 4-cyl. horizontally opposed, normal aspirated engine
<b>Certification</b>	<b>iSc</b> Certified to EASA CS-E (TC No. EASA.E.121)
	<b>iS</b> Non-certified aircraft engines
<b>Configuration</b>	<b>2</b> Prop shaft with flange for fixed prop.
	<b>3</b> Prop shaft with flange for constant speed propeller and drive for hydraulic governor for constant speed propeller.

**Options**

Available options (optional equipment) for the engine type mentioned above:

	external alternator	vacuum pump	governor	exhaust system
<b>for configuration 2</b>	YES	YES	NO	YES
<b>for configuration 3</b>	YES	NO	YES	YES



# BRP-Powertrain

## INSTALLATION MANUAL

### 2.1) Standard version

- Serial production**
- 4-stroke, 4 cylinder horizontally opposed, spark ignition engine, single central camshaft push rods - OHV
  - Liquid cooled cylinder heads
  - Ram air cooled cylinders
  - Dry sump forced lubrication
  - Fully redundant electronic engine management (EMS) includes fuel injection, ignition characteristics, etc.
  - Propeller drive via integrated gearbox with mechanical shock absorber and overload clutch
  - Oil tank
  - Electric starter (12 V 0.8 kW)
  - Fuel pump assy.
- 

**| Optional**

- Preparation for hydraulic governor for constant speed propeller: (configuration 3 only)
  - Exhaust system
  - Cooling air baffle
  - Engine suspension frame
-

# BRP-Powertrain

## INSTALLATION MANUAL

### Auxiliary equipment tested

NOTE: The following equipment is not included as part of the standard engine version!

#### NOTICE

Any equipment not included as part of the standard engine version and so does not be part of the engine is not in the scope of supply.

Components especially developed and tested for this engine are readily available at BRP-Powertrain.

**The following auxiliary equipment has been tested on ROTAX engine type 912 i for safety and durability to the standards of aviation.**

The furnishing of proof in accordance to the latest FAR or EASA has to be conducted by the aircraft manufacturer.

- external alternator
- oil cooler with connections
- coolant radiator
- coolant overflow bottle

### Auxiliary equipment not tested

**The following auxiliary equipment has not been tested on ROTAX engine type 912 i for safety and durability to the standards of aviation.**

#### WARNING

Non-compliance can result in serious injuries or death! The user assumes all risks possibly arising by utilizing auxiliary equipment.



The furnishing of proof in accordance to the latest FAR or EASA has to be conducted by the aircraft manufacturer.

- intake filter
- shock mount

**BRP-Powertrain**  
INSTALLATION MANUAL

### 3) Abbreviations and terms used in this Manual

#### Abbreviations

Abbreviation	Description
*	Reference to another section
	center of gravity
	The drop symbol indicates use of sealing agents, adhesives or lubricants (only in the Illustrated Parts Catalog).
°C	Degrees Celsius (Centigrade)
°F	Degrees Fahrenheit
912 iS	see OM (Type designation)
912 iSc	see OM (Type designation)
A	Ampere
a.c.	alternating current
Ah	Ampere hour
A/C	Aircraft
AD	Airworthiness Directive
A/F	Across-flat dimension
ASB	Alert Service Bulletin
ACG	Austro Control GmbH
AKI	Anti Knock Index
API	American Petrol Institute
ASTM	American Society for Testing and Materials
ATA	Air Transport Association
AWG	American Wire Gauge
BUDS	BRP Utility and Diagnostic Software
CAN	Controller Area Network
CAN/CGSB	Canadian General Standards Board
CPS 1+2	Crankshaft Position Sensor 1+2
CSA	Constant Speed Actuator
CTS	Cooling Temperature Sensor
CW	Clockwise
CCW	Counter-clockwise
DCDI	Dual Capacitor Discharge Ignition
d.c.	direct current
DOA	Design Organisation Approval
DOT	Department of Transport
EASA	European Aviation Safety Agency
ECU	Engine Control Unit
EGT	Exhaust Gas Temperature

d05780.fm

# BRP-Powertrain

## INSTALLATION MANUAL

Abbreviation	Description
EMS	Engine Management System
EN	European Norm
ETFE	Ethylene Tetrafluoroethylene
FAA	Federal Aviation Administration
FAR	Federal Aviation Regulation
hr.	hours
IFR	Instrument Flight Rules
IM	Installation Manual
INJ 1-8	Injector 1-8
INTRO	Introduction
IPC	Illustrated Parts Catalog
iRMT	independent ROTAX Maintenance Technician
ISA	International Standard Atmosphere
kg	kilograms
LEP	List of Effective Pages
MAPS 1+2	Manifold Air Pressure Sensor 1+2
MATS 1+2	Manifold Air Temperature Sensor 1+2
MM	Maintenance Manual
MON	Motor Octane Number
MAG	Magneto Side
N	new part (only Illustrated Parts Catalog)
n.a.	not available
nB	as necessary (only Illustrated Parts Catalog)
NDT	non-destructive testing
Nm	Newtonmeter
OHM	Overhaul Manual
OM	Operators Manual
part no.	Part number
PTFE	Polytetrafluoroethylene
PTO side	power take off side
Rev.	Revision
RON	Research Octane Number
ROTAX	is a trade mark of BRP-Powertrain GmbH & Co KG
rpm	Revolutions per minute
SB	Service Bulletin
SI	Service Instruction
SL	Service Letter
SMD	Surface Mounted Devices

d05780.fm

**BRP-Powertrain**  
INSTALLATION MANUAL

<b>Abbreviation</b>	<b>Description</b>
S/N	Serial Number
s.v.	still valid (only Illustrated Parts Catalog)
TBO	Time Between Overhaul
TOA	Table of amendments
TOC	Table of Contents
TSN	Time Since New
TSNP	Time Since New Part
TSO	Time Since Overhaul
V	Volt
VFR	Visual Flight Rules
XXX	shows the serial component number

d05780.fm

**BRP-Powertrain**  
INSTALLATION MANUAL

**3.1) Conversion table**

<p><b>Units of length:</b>  1 mm = 0.03937 in  1 in = 25.4 mm  1 ft = 12 in  = 0.3048 m</p>	<p><b>Units of power:</b>  1 kW = 1.341 hp  1 hp = 0.7457 kW  1 kW = 1.3596 PS  1 PS = 0.7355 kW</p>																				
<p><b>Units of area:</b>  1 cm<sup>2</sup> = 0.155 sq. in (in<sup>2</sup>)  1 sq. in (in<sup>2</sup>) = 6.4516 cm<sup>2</sup></p>	<p><b>Units of temperature:</b>  K = °C - 273.15  °C = (°F - 32) / 1.8  °F = (°C x 1.8) + 32</p>																				
<p><b>Units of volume:</b>  1 cm<sup>3</sup> = 0.06102 cu in (in<sup>3</sup>)  1 cu in (in<sup>3</sup>) = 16.3871 cm<sup>3</sup> (in<sup>3</sup>)  1 dm<sup>3</sup> = 1 l  1 dm<sup>3</sup> = 0.21997 gal (UK)  1 gal (UK) = 4.5461 dm<sup>3</sup>  1 dm<sup>3</sup> = 0.26417 gal (US)  1 gal (US) = 3.7854 dm<sup>3</sup></p>	<p><b>Units of velocity:</b>  1 m/s = 3.6 km/h  1 ft/min = 0.3048 m/min  = 0.00508 m/sec  1 m/s = 196.85 ft/min  1 kt = 1.852 km/h  1 km/h = 0.53996 kn</p>																				
<p><b>Units of mass:</b>  1 kg = 2.2046 lb  1 lb. = 0.45359 kg</p>	<p><b>spec. fuel consumption:</b>  1 g/kWh = 0.001644 lb/hph  1 lb./hph = 608.277 g/kWh</p>																				
<p><b>Density:</b>  1 g/cm<sup>3</sup> = 0.016018 lb/ft<sup>3</sup>  1 lb/ft<sup>3</sup> = 62.43 g/cm<sup>3</sup></p>	<p><b>Units of torque:</b>  1 Nm = 0.737 ft lb.  = 8.848 in lb.  1 ft lb = 1.356 Nm  1 in lb = 0.113 Nm</p>																				
<p><b>Units of force:</b>  1 N = 0.224809 lbf  1 lbf = 4.4482 N</p>	<p><b>Cable cross-section:</b>  <b>Conversion table-Wire Gauge:</b>  <b>AWG-mm<sup>2</sup></b></p> <table border="1" style="width: 100%; border-collapse: collapse; text-align: center;"> <tr> <td style="width: 10%;">AWG</td> <td>4</td> <td>6</td> <td>8</td> <td>10</td> <td>12</td> <td>14</td> <td>16</td> <td>18</td> <td>20</td> </tr> <tr> <td>mm<sup>2</sup></td> <td>21</td> <td>13</td> <td>8.4</td> <td>5.3</td> <td>3.3</td> <td>2.1</td> <td>1.3</td> <td>0.8</td> <td>0.52</td> </tr> </table>	AWG	4	6	8	10	12	14	16	18	20	mm <sup>2</sup>	21	13	8.4	5.3	3.3	2.1	1.3	0.8	0.52
AWG	4	6	8	10	12	14	16	18	20												
mm <sup>2</sup>	21	13	8.4	5.3	3.3	2.1	1.3	0.8	0.52												
<p><b>Units of pressure:</b>  1 Pa = 1N/m<sup>2</sup>  1 bar = 100000 Pa/1000 hPa/  100 kPa  1 bar = 14.5037 lbf/in<sup>2</sup> (psi)  1 in Hg = 33.8638 hPa</p>																					

d05780.fm

**BRP-Powertrain**  
INSTALLATION MANUAL

#### 4) Safety notice

**General note** Although the reading of such information does not eliminate the hazard, it promotes the understanding and application of the information contained here in for correct use of the engine. Always use common workshop safety practice.

The information and components system descriptions contained in this Manual are correct at the time of publication. BRP-Powertrain maintains a policy of continuous improvement of its products without imposing upon itself any obligation to install them on its products previously manufactured.

---

**Revision** BRP-Powertrain reserves the right at any time, and without incurring obligation, to remove, replace or discontinue any design, specification, feature or otherwise.

---

**Measure** Specifications are given in the SI metric system with the USA equivalent in parenthesis.

---

**Symbols used** This Manual uses the following symbols to emphasize particular information. This information is important and must be observed.



Identifies an instruction which, if not followed, may cause serious injury including the possibility of death.



Identifies an instruction which, if not followed, may cause minor or moderate injury.

**NOTICE**

Denotes an instruction which, if not followed, may severely damage the engine or other component.

**NOTE:** Indicates supplementary information which may be needed to fully complete or understand an instruction.

#### **ENVIRONMENTAL NOTE**

Environmental notes give you tips on environmental behavior.



A revision bar outside of the page margin indicates a change to text or graphic.

**Tip**

This information gives you additional advice and tips.

d05780.fm

# BRP-Powertrain

## INSTALLATION MANUAL

### 4.1) Safety information

Use for intended purpose

 **WARNING**

Non-compliance can result in serious injuries or death!

Only certified technicians (iRMT, see also Maintenance Manual Line) trained on this product are qualified to work on these engines.

 **WARNING**

Non-compliance can result in serious injuries or death!

Never fly the aircraft equipped with this engine at locations, airspeeds, altitudes, or other circumstances from which a successful no-power landing cannot be made, after sudden engine stoppage.

- This engine is not suitable for aerobatics (inverted flight, etc.).
- This engine shall not be used on rotorcrafts with an in-flight driven rotor (e.g. helicopters).
- It should be clearly understood that the choice, selection and use of this particular engine on any aircraft is at the sole discretion and responsibility of the aircraft manufacturer, assembler and owner/user.
- Due to the varying designs, equipment and types of aircraft, BRP-Powertrain grants no warranty or representation on the suitability of its engine's use on any particular aircraft. Further, BRP-Powertrain grants no warranty or representation of this engine's suitability with any other part, component or system which may be selected by the aircraft manufacturer, assembler or user for aircraft application..

 **WARNING**

Non-compliance can result in serious injuries or death!  
For each use of DAY VFR, NIGHT VFR or IFR in an aircraft the applicable legal requirements and other existing regulations must be adhered to.

- In addition to observing the instructions in our Manual, general safety and accident preventative measures, legal regulations and regulations of any aeronautical authority must be observed.
- Where differences exist between this Manual and regulations provided by any authority, the more stringent regulation should be applied.



## BRP-Powertrain

### INSTALLATION MANUAL

- For continuing airworthiness see Maintenance Manual Line.
  - Unauthorized modifications of engine or aircraft will automatically exclude any liability of the manufacturer for sequential damage.
- 

#### Engine run

- In the interest of safety, the aircraft must not be left unattended while the engine is running.
  - To eliminate possible injury or damage, ensure any loose equipment or tools are properly secured before starting the engine.
  - When in storage protect the engine and fuel system from contamination and exposure.
  - Never operate the engine and gearbox without sufficient quantities of lubricating oil.
  - Never exceed the maximum permitted operational limits.
  - Allow the engine to cool at idle for several minutes before turning off the engine.
  - Propeller and its attachment with a moment of inertia in excess of the specified value must not be used and releases the engine manufacturer from any liability.
  - Improper engine installation and use of unsuitable piping for fuel, cooling and lubrication system releases the engine manufacturer from any liability.
-

**BRP-Powertrain**  
INSTALLATION MANUAL

## 4.2) Instruction

<b>General note</b>	<p>Engines require instructions regarding their installation, application, use, operation, maintenance and repair.</p> <p>Technical documentation and directions are useful and necessary complementary elements for personal instruction, but can by no means substitute theoretical and practical instructions.</p> <p>These instructions should cover explanation of the technical context, advice for operation, maintenance, use and operational safety of the engine.</p> <hr/>
<b>Safety notice</b>	<p>In this technical Manual passages concerning safety are especially marked. Pass on safety warnings to other users!</p> <hr/>
<b>Accessories</b>	<p>This engine must only be operated with accessories supplied, recommended and released by BRP-Powertrain. Modifications are only allowed after consent by the engine manufacturer.</p> <hr/>
<b>Spare parts</b>	<p><b>NOTICE</b> Spare parts must meet with the requirements defined by the engine manufacturer. This is only warranted by use of GENUINE-ROTAX spare parts and/or accessories (see IPC) or suitable equivalent in the manufacturer's opinion otherwise, any limited warranty by BRP-Powertrain is null and void (see Warranty Conditions). Spare parts are available at the authorized ROTAX Distributor and their Service Center.</p> <p>Any warranty by BRP-Powertrain becomes null and void if spare parts and or accessories other than GENUINE-ROTAX spare parts and/or accessories are used (see latest Warranty Conditions).</p> <hr/>
<b>Tools</b>	<p><b>NOTICE</b> In principle use only tools and appliances which are either cited in the Manual or in the Illustrated Parts Catalog.</p> <hr/>
<b>State of delivery</b>	<p><b>WARNING</b> Engine and gearbox are delivered in "dry" conditions (without oil). Before putting the engine into operation it must be filled with oil. Use only oil as specified (consult Operators Manual and SI-912 i-001 "Selection of suitable operating fluids" current issue).</p>

d05780.fm

# BRP-Powertrain

## INSTALLATION MANUAL

### 4.3) Technical documentation

<b>General note</b>	<p>These documents form the instructions ensuring continued airworthiness of ROTAX aircraft engines.</p> <p>The information contained is based on data and experience that are considered applicable for authorized mechanics (iRMT, see Maintenance Manual Line) under normal conditions.</p> <p>Due to the fast technical progress and fulfilment of particular specifications of the customers it may occur that existing laws, safety prescriptions, constructional and operational regulations cannot be transferred completely to the object bought, in particular for special constructions, or may not be sufficient.</p>
<b>Documentation</b>	<ul style="list-style-type: none"><li>- Installation Manual</li><li>- Operators Manual</li><li>- Maintenance Manual (Line and Heavy Maintenance)</li><li>- Overhaul Manual</li><li>- Illustrated Parts Catalog</li><li>- Alert Service Bulletin</li><li>- Service Bulletin</li><li>- Service Instruction</li><li>- Service Letter</li></ul> 
<b>Status</b>	<p>The status of the Manuals can be determined with the aid of the table of amendments. The first column indicates the revision state.</p> <p>This figure should be compared with the revision provided on ROTAX-Aircraft Engines Website: <a href="http://www.FLYROTAX.com">www.FLYROTAX.com</a>.</p> <p>Amendments and current versions can be downloaded free of charge.</p>
<b>Replacement pages</b>	<p>Furthermore the Manual is constructed in such a way that single pages can be replaced instead of the complete document. The list of effective pages is given in the chapter LEP. The particular edition and revision number is given on the footer of each page.</p>

d05780.fm

**BRP-Powertrain**  
INSTALLATION MANUAL

**Reference**

**NOTICE**

This Manual for engine installation is only part of the Technical Documentation and will be supplemented by the respective Operators Manual, Maintenance Manual and Illustrated Parts Catalog.

Pay attention to references to other documentation, found in various parts of this Manual.

Any reference to a document refers to the latest edition issued by BRP-Powertrain, if not stated otherwise.

---

**Illustrations**

The illustrations in this Manual are mere sketches and show a typical arrangement. They may not represent in full detail or the exact shape of the parts which have the same or similar function. Therefore deduction of dimensions or other details from illustrations is not permitted.

**NOTE:** The Illustrations in this Manual are stored in a graphic data base system and are provided with a consecutive irrelevant number.

This number (e.g. 00277) is of no significance for the content.

---

**Installation drawings**

Installation drawings and a DMU-model for (virtual) installation analysis are available from the ROTAX Authorized Distributors or their Service Centers.

---

# BRP-Powertrain

## INSTALLATION MANUAL

Graphic

Installation drawing

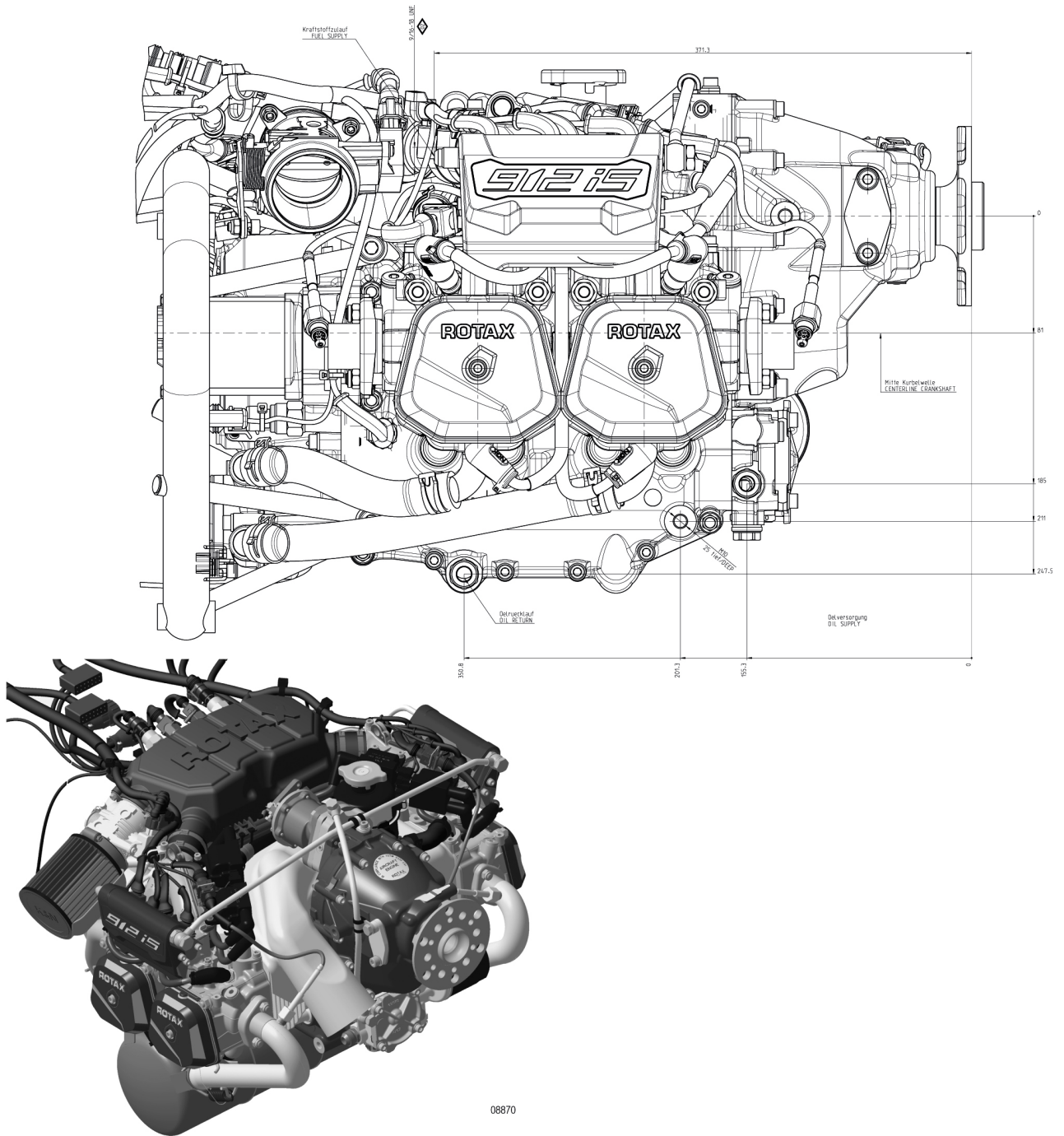

d05780\_fm

Effectivity: 912 i Series  
Edition 1/Rev. 0

00-00-00

page 17  
January 01/2012

**BRP-Powertrain**  
INSTALLATION MANUAL

NOTES

d05780.fm

**BRP-Powertrain**  
INSTALLATION MANUAL

**Chapter: 10-10-00**  
**STORAGE AND INSTALLATION**

**Introduction**

**NOTICE**

The stated directives are measures that must be observed during every engine installation to prevent any accidents and engine damage.

**Table of contents**

This section of the installation manual contains state of delivery, transport, storage and aircraft engine installation.

Subject	Page
Preparations for engine installation	<a href="#">Page 3</a>
State of delivery	<a href="#">Page 3</a>
Unpacking/handling of the engine	<a href="#">Page 3</a>
Preservation and storage of the engine	<a href="#">Page 4</a>
Protective coverings	<a href="#">Page 4</a>
Engine suspension and installation position	<a href="#">Page 6</a>
Engine suspension instructions	<a href="#">Page 6</a>
Attachment points	<a href="#">Page 8</a>
Definition of attachment points	<a href="#">Page 9</a>
Permissible installation positions	<a href="#">Page 11</a>

**BRP-Powertrain**  
INSTALLATION MANUAL

NOTES



## 1) Preparations for engine installation

### 1.1) State of delivery

Attachment

**NOTICE**

Risk of consequential damage to engine and aircraft as a result of corrosion and damage.  
Under no circumstances is a corroded or damaged engine to be installed in an aircraft!

**NOTICE**

The attachment screws are only for transport and must not be used in the aircraft.

The engine can be attached with steel angles anchored on a timber plate.

- When the engine is delivered, check that the GENUINE-ROTAX packing is not damaged.
  - If the packing is damaged, contact the authorized distributor- or Service Center for ROTAX aircraft engines.
- 

### 1.2) Unpacking/handling of the engine

Unpacking the engine

To unpack a new engine, proceed as follows:

Step	Procedure
1	Remove the wooden cover.
2	Remove the protective packaging.
3	Remove the protective film around the engine.

---

After unpacking

To check the state of delivery, proceed as follows:

Step	Procedure
1	Check that the serial number and engine type designation on the type plate are identical to those shown on the delivery note.
2	Check the engine for damage or corrosion. If everything is deemed "OK", the engine can be accepted.

---

Suspension point

The engine is attached to the pivot point (A) of the governor using a special tool and lifted up to the intake manifolds using two straps or hooks. See [Fig. 1](#)

**NOTICE**

Do not use the fuel line assy. to lift the engine!

---

**BRP-Powertrain**  
INSTALLATION MANUAL

Graphic

Governor pivot point (A)

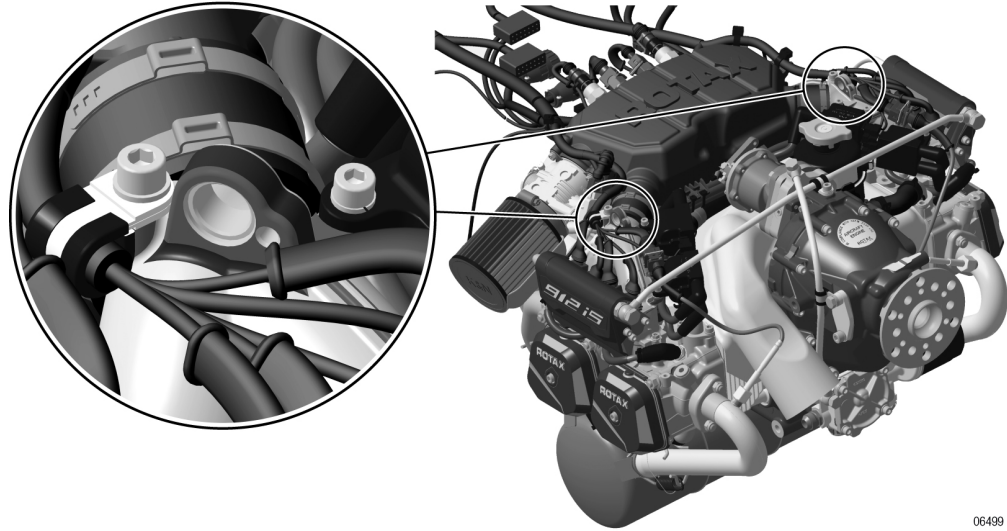

*Fig. 1*

---

### 1.3) Preservation and storage of the engine

**General note** The engine is preserved at BRP-Powertrain thus guaranteeing proper protection against corrosion damage for at least 24 months after the date of delivery from BRP-Powertrain.

---

**Warranty** This warranty is subject to the following conditions:

- The engine must be stored in the GENUINE-ROTAX packing as supplied by BRP-Powertrain.
- The covers on various openings must not be removed.
- The engine must be stored in a suitable place (at min. -40 °C/-40 °F and max. +80 °C/176 °F).
- The flat bag (blue) surrounding the engine must not be damaged or removed, as it protects the engine from corrosion and oxidation.

---

**Storage** If the engine is stored for a period longer than 12 months (not stored in the GENUINE-ROTAX packing) then maintenance tasks must be carried out every 3 months as per the currently valid Maintenance Manual, section "Preservation of a new engine".

---

### 1.4) Protective coverings

**General note** **NOTICE** Protective coverings are only for use during transport and engine installation. They must be removed before the engine is operated.

# BRP-Powertrain

## INSTALLATION MANUAL

All openings are protected against ingress of contamination and dampness. It is recommended to leave the protective plugs in place until installation of the specific feed line.

**NOTE:** The transport equipment and plugs must be reattached if the engine will be sent to the manufacturer or distributor.

### Protective coverings

List of protective coverings. See [Fig. 2](#).

Pos.	Installation location
1	Exhaust sockets
2	Fuel rail (outlet) / fuel pressure regulator
3	Fuel rail (inlet)
4	Oil inlet/outlet
5	Supply and discharge of coolant
6	Throttle valve support assy.
7	Propeller shaft

### Graphic

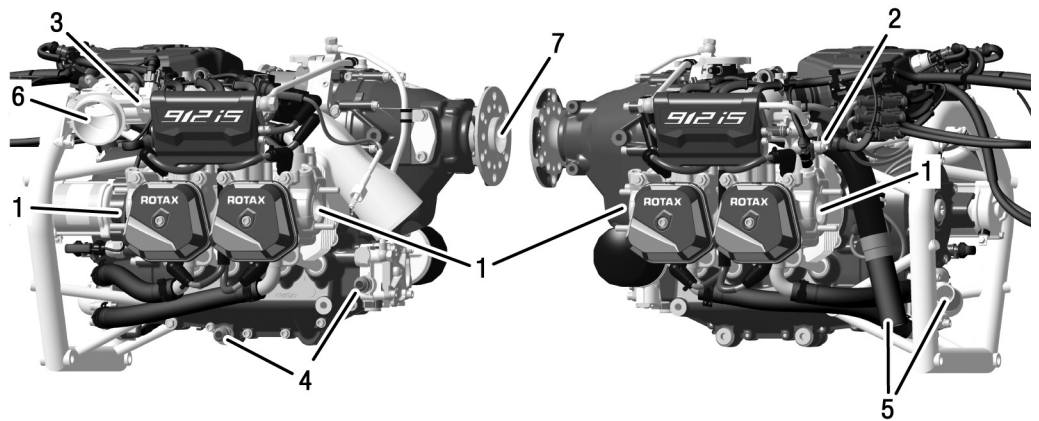

06498

*Fig. 2*

## 2) Engine suspension and installation position

**General note** **NOTICE** During engine installation take into account the total engine weight and ensure careful handling.

---

**Engine suspension** The engine suspension is essentially determined by the aircraft design. Eight attachment points are provided (4 on the engine if the ring mount is used, if not: 2 on the engine and 2 on the engine suspension frame).

---

**Engine suspension frame** **NOTICE** If the engine suspension frame is not used or if modified, certification in accordance with the latest regulations, such as FAR or EASA, must be conducted by the aircraft manufacturer.

The engine is supplied with a tested and certified suspension frame for the fireproof bulk head. Installation in the aircraft is carried out using standard captive rubber mounts which also isolate vibration and noise from the aircraft frame.

---

### 2.1) Engine suspension instructions

**General note** **NOTICE** The rubber mounts for neutralising vibrations and all engine suspension components not in the scope of delivery must be ground run tested at the specified loads and tested for vibration behaviour. Certification to the latest regulations, such as FAR and EASA, must be conducted by the aircraft manufacturer.

---

**Noise emission and vibration** **NOTICE** The engine suspension must be designed to prevent excessive engine movement and to minimise noise emission and vibration on the airframe.

**NOTICE** If the GENUINE-ROTAX engine suspension frame is not being used, a vibration test must be carried out. See SL-912-010.

# BRP-Powertrain

## INSTALLATION MANUAL

**NOTE:** With suspension on the 4 top lugs L3, R3, L4 and R4 only, the tilting moment due to the pull of the propeller will be avoided while, if attached on the bottom lugs only, the moment of tilting has to be taken care of accordingly.

Standard aircraft industry damping elements (e.g. Lord) are suitable. See [Fig. 3](#).

### Graphic

### Engine suspension

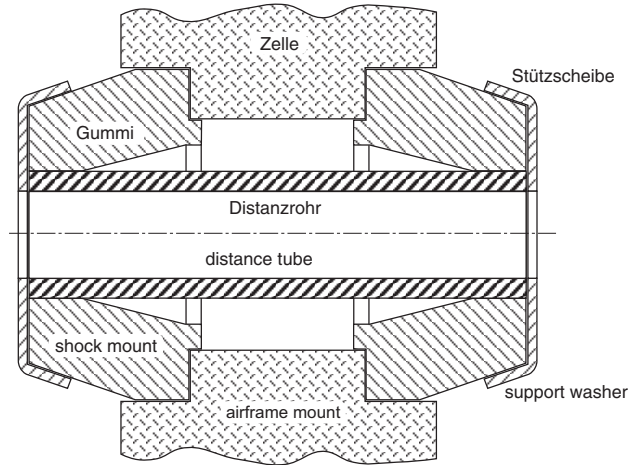

**NOTE:** The illustration shows Lord j 3608-1 or J 3608-2 rubber mounts. Consult the manufacturer for the dimensions of the rubber mounts.

*Fig. 3*

07600

### Vibration neutralisation

The vibration and acoustic insulation factor is dependent on the cell manufacturer. Perform the determination as described in SL-912-010.

### Damping elements

**NOTICE**

All elements for neutralising vibrations must be captive.

### Vertical axis

The y-axis must be perpendicular to the longitudinal axis of the aircraft.

### Deviation

Permissible deviation from perpendicular:  $\pm 10^\circ$ .  
See [Fig. 4](#).

d05165.fm

**BRP-Powertrain**  
INSTALLATION MANUAL

Graphic

Deviation

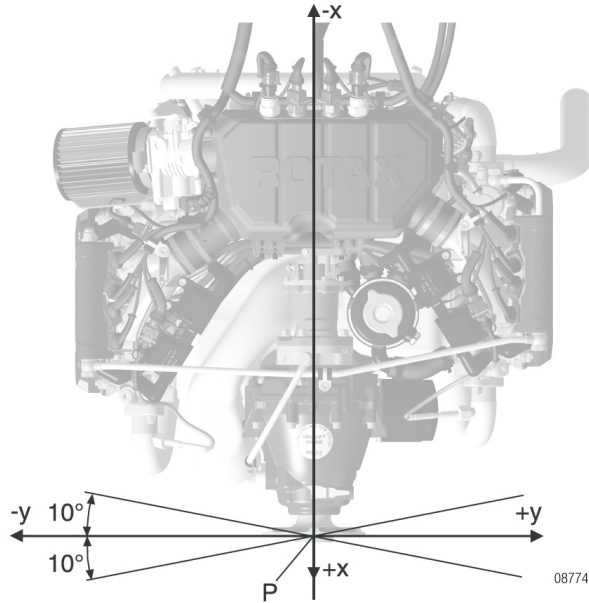

*Fig. 4*

---

## 2.2) Attachment points

General note

See [Fig. 5](#).

**NOTICE**

The hex. screws M10x60 in the attachment points are for transport only and must not be used for engine suspension.

It is recommended that the 4 stated attachment points R2, L2, R3 and L3 of the engine suspension frame are used.

**NOTICE**

A minimum of 4 attachment points must be used. These must be distributed symmetrically between the left (L) and right (R) sides.

## 2.3) Definition of attachment points

General note See Fig. 5.

**⚠ WARNING**

Non-compliance can result in serious injuries or death!

The aircraft or fuselage manufacturer must design the engine suspension so that it can safely carry the maximum occurring operational loads without exceeding the max. allowable forces and bending moments on the engine housing and attachment points.

Tighten all engine suspension screws as specified by the aircraft manufacturer.

Graphic

Attachment points

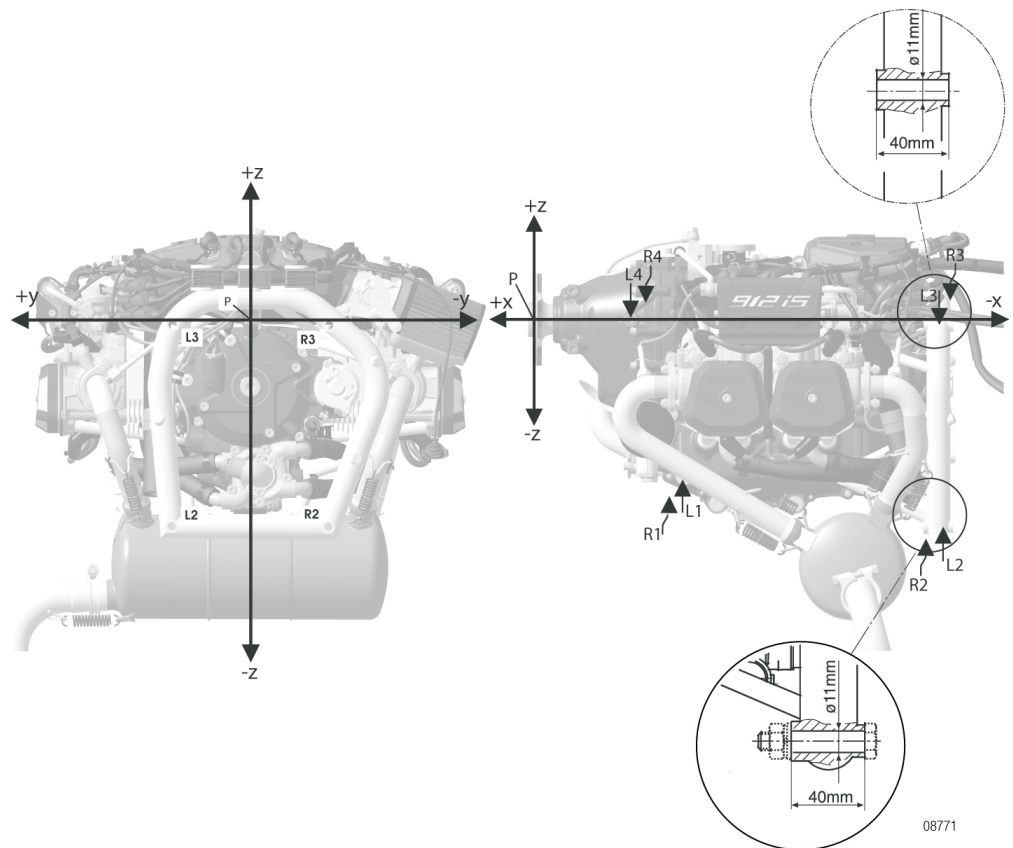

Fig. 5

d05165.fm

**BRP-Powertrain**  
INSTALLATION MANUAL

Attachment points	x-axis mm/in	y-axis mm/in	z-axis mm/in
L1	-200.8/-7.90	-71.0/-2.80	-211.0/-8.31
R1	-200.8/-7.90	-71.0/-2.80	-211.0/-8.31
L2	-564.0/-22.20	105.0/4.13	-277.0/-10.91
R2	-564.0/-22.20	-105.0/-4.13	-277.0/-10.91
L3	-564.0/-22.20	105.0/4.13	-7.0/-0.28
R3	-564.0/-22.20	-105.0/-4.13	-7.0/-0.28
L4	-128.3/-5.05	87.0/3.43	0
R4	-128.3/-5.05	-87.0/-3.43	0

Attachment points	Max. permissible force (secure load) in (N) in. x, y, and z axis	Max. permissible bending mo- ment (secure load) in (Nm) in. x, y, and z axis
L1	5000/196.85	77/3.03
R1		
L4	1900/74.80	39/1.54
R4		

Attach- ment points	Max. permissi- ble force (secure load) in (N) in. x axis	Max. permissi- ble bending mo- ment (secure load) in (N) in. y axis	Max. permissi- ble bending mo- ment (secure load) in (N) in. z axis	Max. permissi- ble bending mo- ment (secure load) in (Nm) in. x, y and z axis
L2	5000/196.85	2000/78.74	3000/118.11	100/3.94
R2				
L3				
R3				

Attachment points	Thread	Max. usable Thread length
L1	M10	25 mm/0.98 in.
R1		
L4	M10	16 mm/0.63 in.
R4		

d05165.fm



## 2.4) Permissible installation positions

### General note

**NOTICE**

The oil system, fuel system and the cooling system are unsuitable for upside-down/inverted installation of the engine.

NOTE: Dimensions are always from zero reference point and the coordinate system position remains unchanged.

### Installation positions

The following installation position details refer to the aircraft in parked position (aircraft on ground, ready for take off).

- Engine suitable for propeller in tractor or pusher arrangement
- Installation only with propeller shaft above cylinders

### Propeller axis

The centres of attachment points L1 and R1 must be on a  $y_2$  axis parallel to the  $y$ -axis.

**Permissible deviation from parallel:  $\pm 5^\circ$**

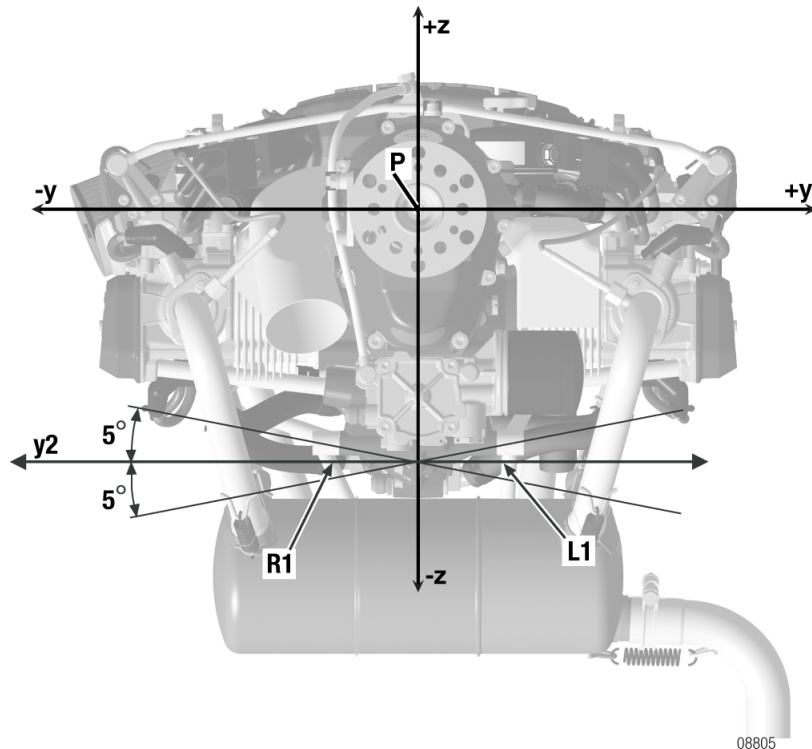
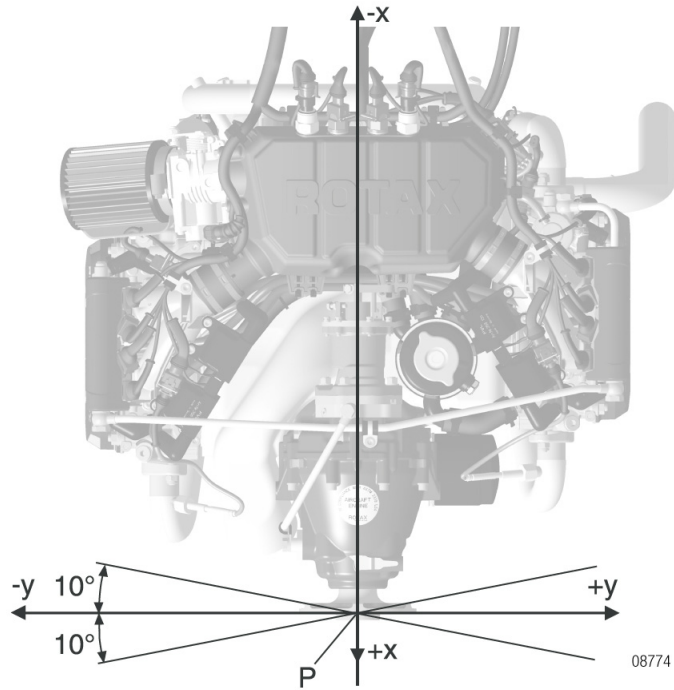

Fig. 6

**BRP-Powertrain**  
INSTALLATION MANUAL

**Vertical axis** The y-axis must be perpendicular to the longitudinal axis of the aircraft.  
**Permissible deviation from perpendicular:  $\pm 10^\circ$**



*Fig. 7*

# BRP-Powertrain

## INSTALLATION MANUAL

### Chapter: 24-00-00

### ELECTRICAL SYSTEM

#### Introduction

This section describes the general requirements for the circuit wiring, electromagnetic compatibility, grounding cables, battery and optional components. More details can be found in the Overhaul Manual.

#### Table of contents

This section of the installation manual lists the electrical and wiring diagrams of the aircraft engine.

Subject	Page
Requirements for the circuit wiring	Page 3
Approval of electric and electronic components	Page 4
Battery	Page 5
Technical data	Page 5
Grounding cables (EMS ground point/engine/ground point)	Page 7
Controller boards on the FUSE BOX	Page 8
FUSE BOX connections	Page 10
Technical data and connection of the electric components	Page 11
Internal generator	Page 11
Rectifier regulator	Page 13
External alternator (optional extra)	Page 15
Technical data	Page 15
Connections	Page 15
Requirements for correct operation of the integrated rectifier regulator	Page 16
Wiring diagram: External alternator	Page 18
Wiring harness	Page 19
Fitting the Faston connector to the Harness Interface Connector	Page 20
Switch and warning lamp requirements	Page 23
TIPS: Wiring Powerside (optional)	Page 26
Wiring diagram	Page 29
Wiring diagram: EMS	Page 31
Wiring diagram: Wiring Powerside	Page 32
Wiring diagram: Wiring Powerside (optional)	Page 33
Wiring diagram: Wiring HIC switch and warning lamps	Page 34
Internal power consumers	Page 35

**BRP-Powertrain**  
INSTALLATION MANUAL

NOTES

# BRP-Powertrain

## INSTALLATION MANUAL

### 1) Requirements for the circuit wiring

#### General note

#### **NOTICE**

The connections have to be made by the aircraft manufacturer in accordance with applicable regulations and the enclosed wiring diagram.

See chap. 24-00-00 section:

Switch requirements and warning lamps.

#### **NOTICE**

The power supply to the various consumers (e.g. battery) must be adequately protected by fuses. Using incorrectly rated fuses may result in destruction of the equipment.

Under no circumstances must consumer cables (e.g. battery) be routed alongside the ignition cable. There is a risk of electromagnetic interference or damage.

#### **NOTICE**

Do not bend, kink, pinch or otherwise improperly stress the wiring harness. Use proper routing, clamping and strain relief on wiring harnesses.

#### NOTE:

Follow the relevant building regulations (licensing conditions) of the maintenance staff, during manufacturing of the wiring harness and repairs or modifications of the aircraft.

**BRP-Powertrain**  
INSTALLATION MANUAL

**1.1) Approval of electric and electronic components  
(Equipment Qualification according to RTCA/DO-160)**

**RTCA/DO-160** RTCA/DO-160 defines a series of minimum standard environmental test conditions and applicable test procedures for airborne equipment. The purpose of these tests is to provide a laboratory means of determining the performance characteristics of airborne equipment in environmental conditions representative of those which may be encountered in airborne operation of the equipment.

Electric and Electronic components (incl. wiring harness, ECU, Fuse Box, PMA, Sensors and Actuators) of the 912 iS / 912 iSc are deemed to be part of the Equipment and therefore tested and qualified according to the following table:

DO-160G, Section 4 - Temperature and Altitude	Cat. B3V*
DO-160G, Section 5 - Temperature Variation	Cat.B
DO-160G, Section 6 - Humidity	Cat.B
DO-160G, Section 7 - Operational Shocks and Crash Safety	Cat.B
DO-160G, Section 8 - Vibration	Cat.S (L general, M for ECU)
DO-160G, Section 9 - Explosion Proofness	X
DO-160G, Section 10 - Water Proofness	Cat. S
DO-160G, Section 11 - Fluids Susceptibility	Cat. F
DO-160G, Section 12 - Sand and Dust	Cat. D
DO-160G, Section 13 - Fungus Resistance	X
DO-160G, Section 14 - Salt Spray	Cat. S
DO-160G, Section 15 - Magnetic Effect	Cat. A
DO-160G, Section 16 - Power Input	Cat.BXX
DO-160G, Section 17 - Voltage Spike	Cat.B
DO-160G, Section 18 - AF Cond. Susceptibility	Cat. Z
DO-160G, Section 19 - Induced Signal Susceptibility §19.3.5 Spikes Induced Into Interconnecting Cables	Cat. ZC
DO-160G, Section 20 - RF Susceptibility	Cat. R
DO-160G, Section 21 - Emission RF Energy	Cat.B
DO-160G, Section 22 - Lightning Induced Trans. Suscept.	Cat. A3G3L3
DO-160G, Section 23 - Lightning Direct Effects	X
DO-160G, Section 24 - Icing	X
DO-160G, Section 25 - Electrostatic Discharge	Cat. A

X.....Test not performed

\* .....Components were tested at „operating low temperature“ of - 25° C (- 13° F) instead of - 45° C (- 49° F) and „Altitude“ of 18.000 ft instead of 25.000 ft.

d05781.fm

## 1.2) Battery

### 1.2.1) Technical data

**General note**

**NOTICE**

The size of the battery will need to be adequate for essential flight equipment for the time defined in the airworthiness requirements.

When sizing the battery ensure that during each operating state and also during the transition between two operation states a sufficient supply of the display is guaranteed (e. g. during engine start).

Furthermore, it must be ensured that at least 30 minutes after failure of the primary power supply the display is supplied with sufficient energy, if it is necessary for a safe operation of the aircraft.

**NOTICE**

If the aircraft is regularly used at temperatures below -5 °C (23 °F) (i.e. the engine start is carried out at these engine and ambient temperatures) it is recommended to provide a connection for an external power supply and that adequate engine pre-heating is applied.

**Specification**

Nominal voltage	12 V
Internal resistance	Maximal 10 mΩ at -18 °C (-0.4 F°)
Capacity	At least 16 Ah
Cold Cranking Ampere (cca)	At least 350 A at -18 °C (-0.4 F°) (SAE J537)

**NOTE:**

The responsibility to use a lower capacity battery is up to the aircraft manufacturer. It should be noted that additional electrical loads, which are in some cases required by law, affect the battery performance during the starting process, (e.g. ACL (Anti Collision Light), Navigation Light, Avionic).

**NOTICE**

The use of rechargeable batteries with lithium, ion technology is not permitted unless a suitable battery management system is available and can be used. The responsibility is up to the aircraft manufacturer. The consent and approval of the relevant aeronautical authority is necessary.

## BRP-Powertrain

### INSTALLATION MANUAL

**NOTE:** The battery must be selected so that there is a min. voltage of 9 V on the ECU during start-up (also in cold weather conditions). The engine bus voltage is displayed via the CAN BUS. It can also be displayed using the BUDS Aircraft diagnostic tool.

**NOTE:** Whether the required minimum voltage of 9 V is actually observed (e. g. during engine start) can only be determined with an oscilloscope.

#### **NOTICE**

It must remain displayed during the electric starter operation.

During its first installation in an aircraft model, the voltage must be measured at 3 places.

- Battery voltage (separate voltmeter)
- Voltage on electric starter (separate voltmeter)
- Engine bus voltage (displayed in BUDS diagnostic tool or on display).

#### **NOTICE**

The connection from the battery to the EMS system must be kept separate from the one to the starter relay in order to avoid unnecessary voltage drop.



# BRP-Powertrain

## INSTALLATION MANUAL

### 2) Grounding cables (EMS ground point/aircraft ground point)

#### Introduction

During installation, a distinction is made between 2 circuits

- Aircraft circuit
- Electronic engine management circuit (EMS circuit).

At the engine start (dynamic condition), the two circuits are connected to each other through the FUSE BOX.

The routing of the grounding cables (EMS ground and aircraft ground) is an essential point to be considered when installing the engine electronics.

#### NOTICE

In the static condition (LANE select SW: "**OFF**" engine not running), the EMS ground and the aircraft ground must not be connected. Components that are connected to the EMS ground must be installed in such a way that they are isolated from the aircraft ground.

Components that must not be connected to the aircraft ground or that can be decoupled from the firewall or in the cockpit:

- ECU (must be installed in the cockpit or an area protected from fire and water/humidity)
- Regulator A of FUSE BOX (the fuse box must be mounted in the engine compartment only)
- Starter relay (firewall)

#### Checks

For checking purposes, use a multimeter to carry out a continuity test between rectifier regulator A and rectifier regulator B in the static condition.

NOTE: A continuity must not be present. See [Fig. 1](#).

NOTE: EMS ground must be mounted to the regulator plate A (heat sink of the fuse box) only.

Aircraft ground must be mounted on the regulator plate B (heat sink of the fuse box) only.

**BRP-Powertrain**  
INSTALLATION MANUAL

Graphic

Continuity check

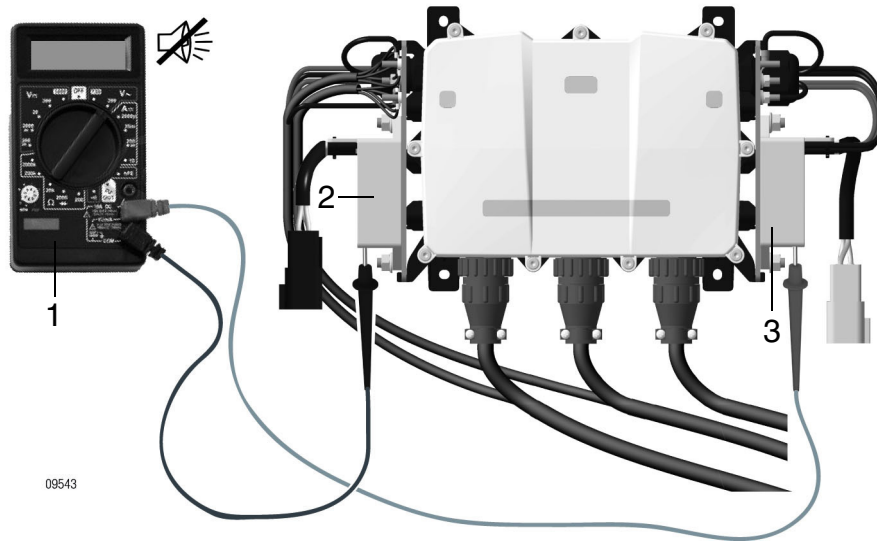

Part	Function
1	Multimeter
2	Rectifier regulator A (black wire connector)
3	Rectifier regulator B (grey wire connector)

*Fig. 1*

## 2.1) Controller boards on the FUSE BOX

See [Fig. 2](#) and [Fig. 3](#).

The EMS grounding cables of the wiring harness (labelled: "Regulator A" or cables with cable lugs) must be connected to the 3 attachment points of the EMS ground. Each side of the FUSE BOX has three ground connections.

EMS ground has 3 interconnected ground connections which may be used interchangeably.

Airframe ground, also has 3 interconnected ground connections which may be used interchangeably, one of which must be connected to the airframe ground.

NOTE: Airframe ground is independent of EMS ground and must NOT be interconnected.

**NOTICE**

The tightening torque of the nuts to secure the EMS grounding cables and the airframe ground of the respective attachment points must be 1.2 Nm (10.7 in.lb).

d05781.fm

**BRP-Powertrain**  
INSTALLATION MANUAL

Graphic

FUSE BOX

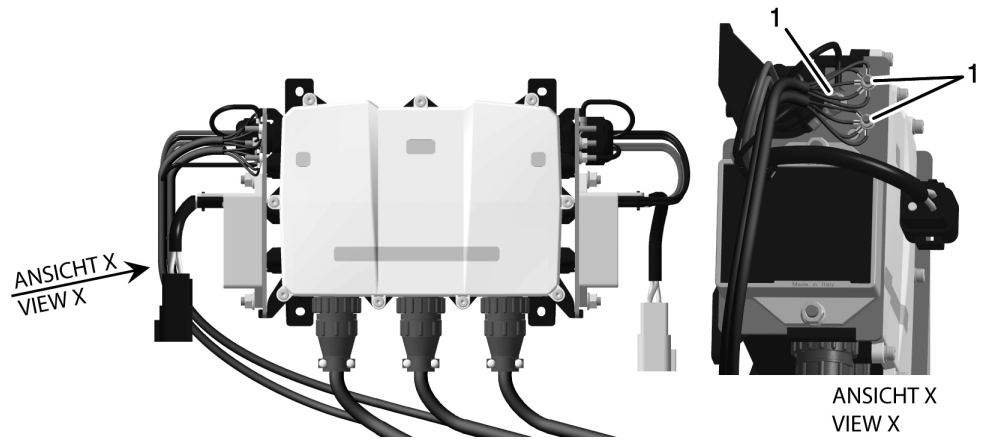

Part	Function
1	EMS ground attachment points

*Fig. 2*

09544

d05781.fm

**BRP-Powertrain**  
INSTALLATION MANUAL

**2.2) FUSE BOX connections**

Graphic

Connections

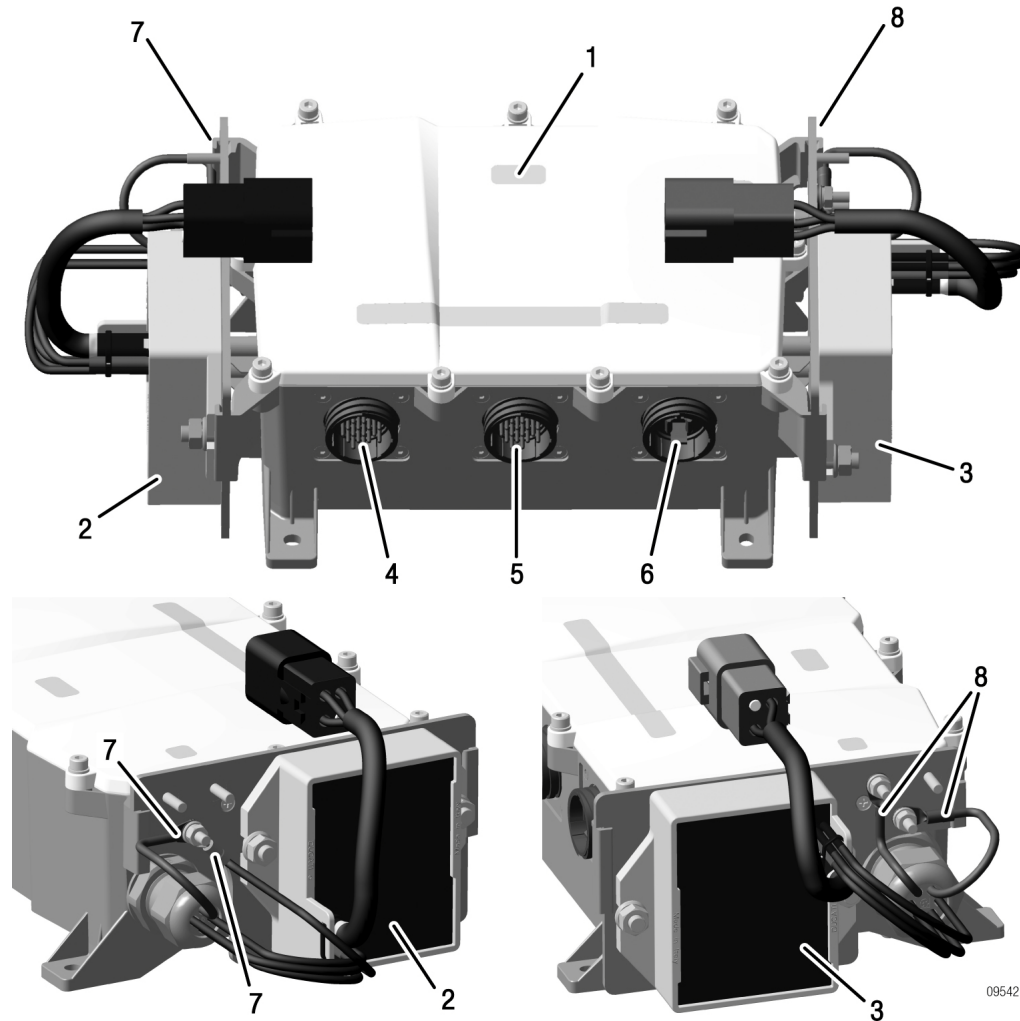

09542

Part	Function
1	FUSE BOX assy.
2	Rectifier regulator A (black plug)
3	Rectifier regulator B (grey plug)
4	Plug connection X1 (LANE A)
5	Plug connection X2 (LANE B)
6	Plug connection X3
7	EMS ground (Generator A)
8	Aircraft ground (Generator B)

*Fig. 3*

d05781.fm

### 3) Technical data and connection of the electric components

#### 3.1) Internal generator

**General note** See Fig. 4.

The internal generator has two isolated coils integrated (individual generators). During the starting operation, the EMS system is powered by the battery. With sufficient speed generator B takes over this function. After the EMS system check, generator A takes over the supply of the EMS system (engine), if the switching threshold is exceeded. Generator B is then used to supply the aircraft instruments and for charging the battery.

- Generator A 14.2 V/16 A (220 W nominal capacity at 20°C/68 °F)
- Generator B 14.2 V/30 A (420 W nominal capacity at 20°C/68 °F)

**NOTICE**

If generator A fails, generator B takes over its functions. The onboard computer and the instruments will be supplied by the battery. The battery will no longer be charged!

**NOTICE**

If generator B fails, the battery will no longer be charged. The engine still runs on generator A and the instruments will be supplied by the battery. The function of the instruments depends on the state of charge of the battery.

For monitoring the battery voltage and to ensure that the battery is charged, a voltmeter and ammeter is necessary.

**Graphic**

Performance diagram showing engine speed against amps

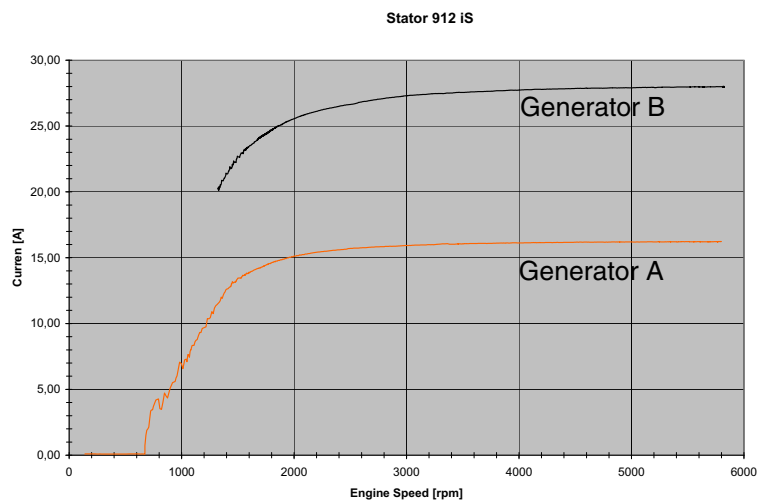

**Fig. 4**

06591

d05781.fm

**BRP-Powertrain**  
INSTALLATION MANUAL

**NOTE:** The measurement is taken at an oil temperature of 135 °C (275 °F).

**Connections**

See [Fig. 5](#).

Power supply wires (1) from the internal generator (exciting from the left side (cylinders 2/4) of the ignition housing) to the regulators on FUSE BOX.

DEUTSCH connector:

- black for generator A/regulator A
- grey for generator B/regulator B

**Graphic**

Connections

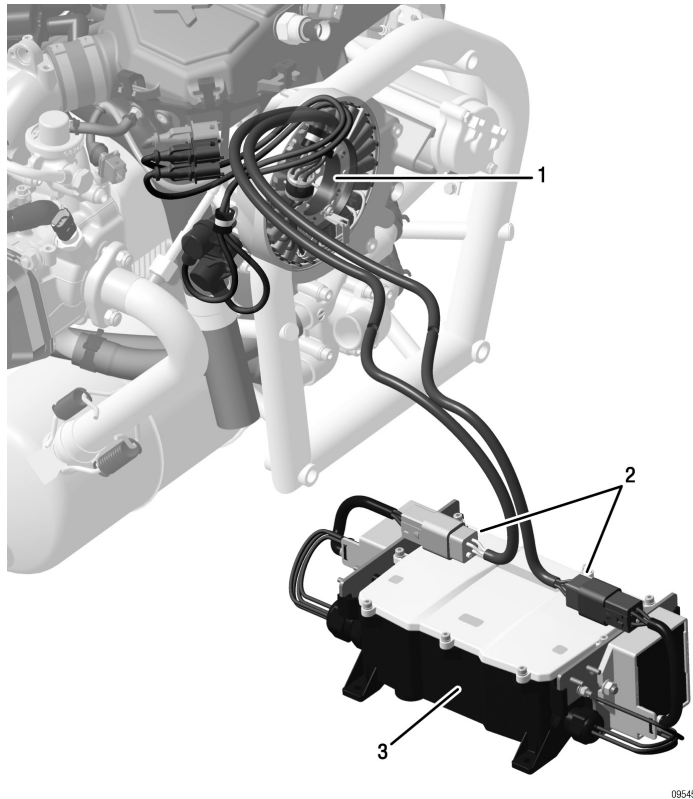

Part	Function
1	Stator
2	DEUTSCH connector
3	FUSE BOX with rectifier regulator

*Fig. 5*

**BRP-Powertrain**  
INSTALLATION MANUAL

**3.2) Rectifier regulator**

See Fig. 6.

<b>Version</b>	Three-phase short rectifier regulator.
<b>Output voltage</b>	14.2 V $\pm$ 0.3 (from 1000 $\pm$ 250 r.p.m).
<b>Component temperature</b>	Max. permissible component temperature: 80 °C (176 °F) (measured in area (2)). NOTE: The performance specifications are given for optimal cooled components.
<b>Weight</b>	See chap. 72-00-00 section 2) Subsection 2.1: Weight.
<b>Graphic</b>	Component temperature measurement area

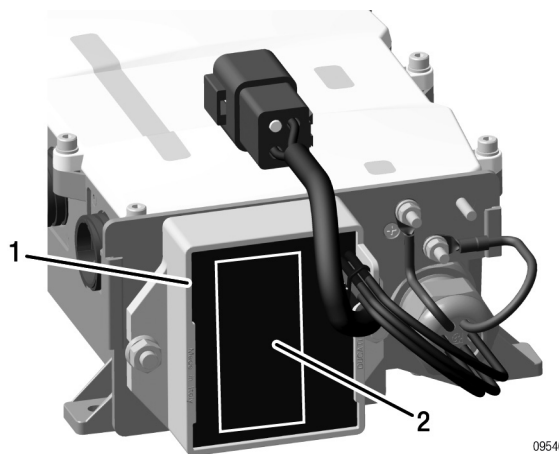

Part	Function
1	Rectifier regulator
2	Component temperature measuring area

*Fig. 6*

06385

d05781.fm

**BRP-Powertrain**  
INSTALLATION MANUAL

NOTES



**BRP-Powertrain**  
INSTALLATION MANUAL

#### 4) External alternator (optional extra)

General note See Fig. 7.

##### 4.1) Technical data

General note NOTE: The voltage regulator is integrated in the alternator.

---

**Output** Output: Max. 550 W/DC at 6000 r.p.m. (complies ~ 4800 r.p.m. crankshaft speed)

---

**Output voltage** Output voltage: 13.5 V

---

**Ambient temperature range** Ambient temperature: Min. -30 °C (-22 °F)  
Max. +90 °C (194 °F)

---

**Weight** See chap. 72-00-00 section 2) Subsection 2.1: Weight.

---

##### 4.2) Connections

**Power supply wires** Power supply wires to external alternator (1) have to be installed depending on the mounting position and according to the regulations of the aircraft manufacturer.

---

**Positive terminal** Positive terminal (2):  
- M6 screw connection suitable for cable terminal according to DIN 46225 (tightening torque 4 Nm (35 in.lb)).

---

**Grounding** Via engine block.

---

**Control wiring** Control wiring (3):  
- via supplied standard plug (Sumitomo 6111-2568) and 6.3 x 0.8 Faston connectors (female).

---

**BRP-Powertrain**  
INSTALLATION MANUAL

Graphic

External alternator

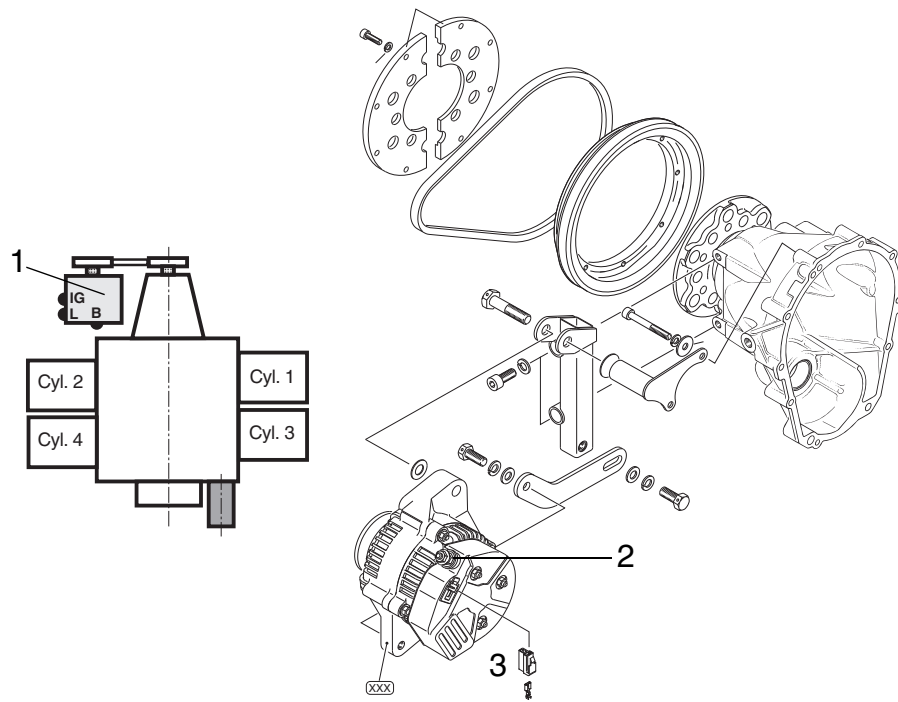

Part	Function
1	External alternator
2	Positive terminal
3	Control wiring

Fig. 7

03199,02764,00547

**4.2.1) Requirements for correct operation of the integrated rectifier regulator**

**Fuse**

The rectifier regulator must be protected by a slow blowing fuse or circuit breaker. Fuse or circuit breaker rating must be determined by load, wire size and length.

**Load distribution**

Due to slightly different output voltages of the regulators (alternator and regulator A/B of fuse box) the power is drawn by the generator with the higher output voltage at low load.

d05781.fm

# BRP-Powertrain

## INSTALLATION MANUAL

### Amperage

#### NOTICE

The current over engine speed graph was determined and is only effective under the following conditions:

- Ambient temperature: 20 °C (68 °F)
- Voltage: constant 13.5 V
- Tolerance: max. ± 5 %

NOTE: The speed of the external alternator is 1.24 times the crankshaft speed or 3 times the propeller speed.

### Graphic

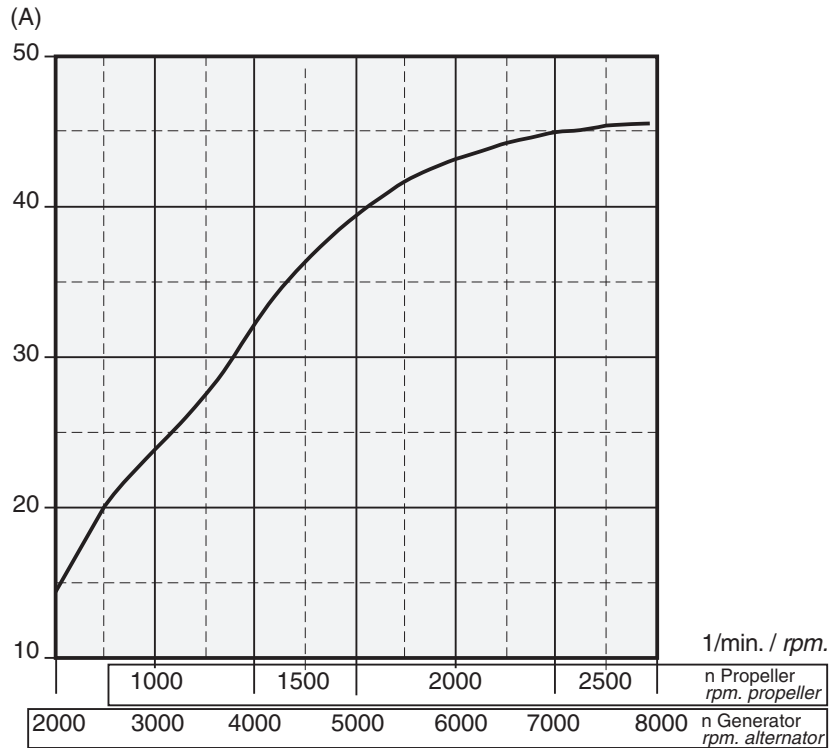

Fig. 8

00547

d05781.fm



**ROTAX**  
AIRCRAFT ENGINES

- AWG 04 (21,1 mm<sup>2</sup>)
  - AWG 12 (3,3 mm<sup>2</sup>)
  - AWG 16 (1,50 mm<sup>2</sup>)
  - AWG 18 (1,00 mm<sup>2</sup>)
  - AWG 20 (0,75 mm<sup>2</sup>)
- 912 iS wiring harness
  - Optional (not required)
  - Airframe Ground
  - EMS ground

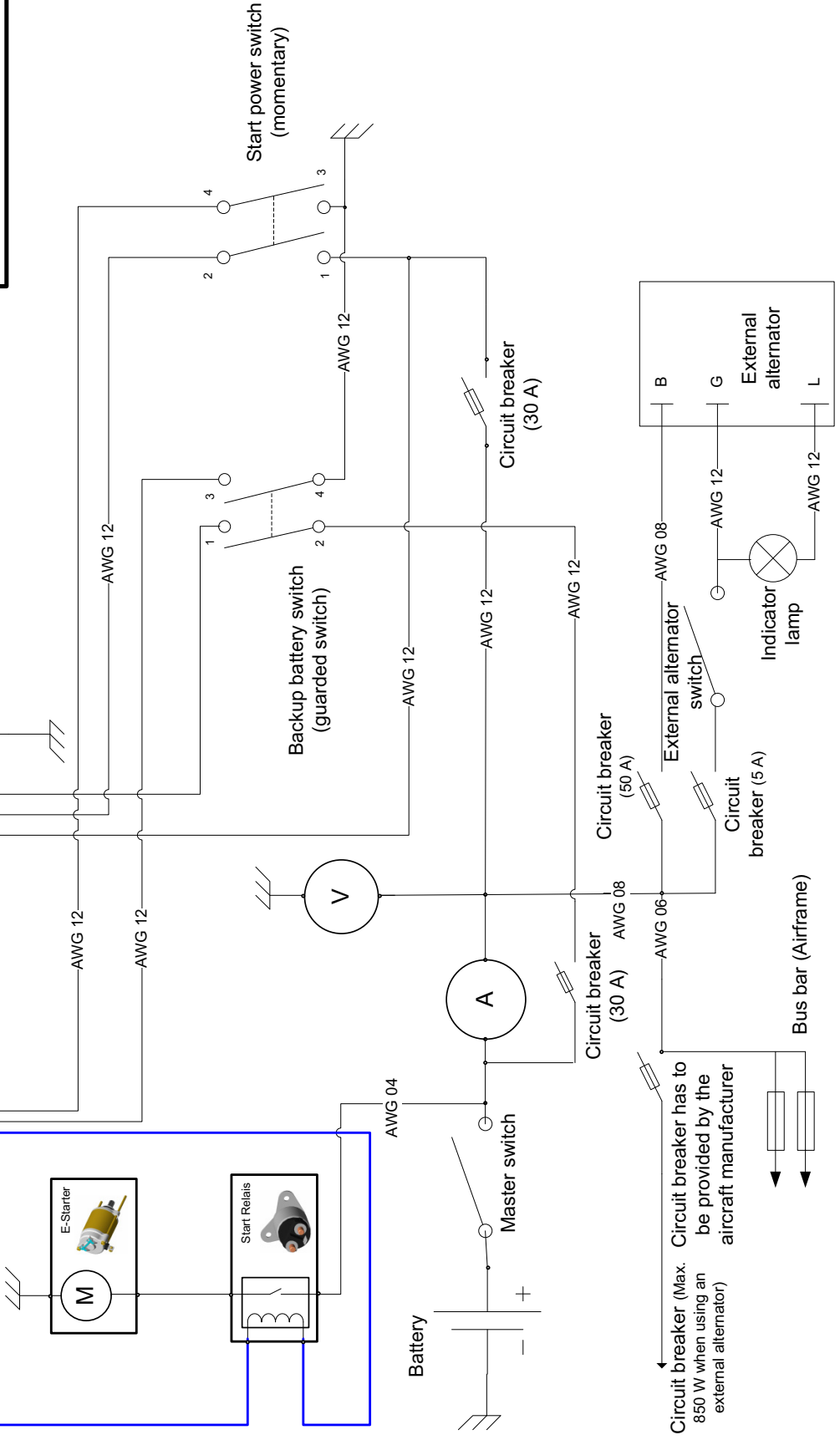
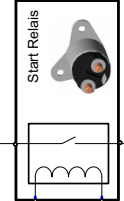
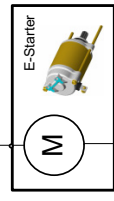
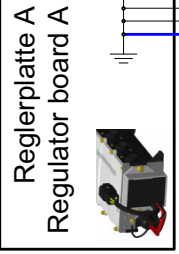
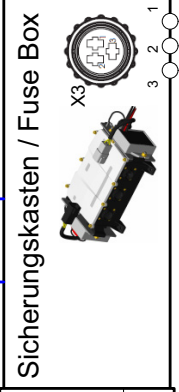
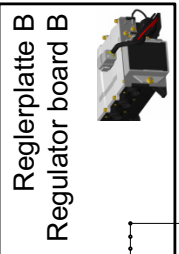
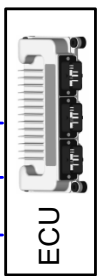

← Circuit breaker (Max. 850 W when using an external alternator) has to be provided by the aircraft manufacturer

**BRP-Powertrain**  
INSTALLATION MANUAL

## 5) Wiring harness

The wiring harness connects the engine control and the

- Control unit (ECU)
- FUSE BOX assy.
- Cockpit (switch, instruments, maintenance connection)
- Engine (sensors, injectors, ignition coils)

**NOTICE**

The wiring harness must not be shortened or modified.

**Sensors**

The sensors are fitted by BRP-Powertrain and connected to the wiring harness. The exhaust gas temperature sensors are included according to the version or already fitted on GENUINE-ROTAX exhaust systems.

**ECU/FUSE BOX connector**

Install and lock the connectors of the ECU and/or FUSE BOX with gasket.

NOTE: Connectors with gasket difficult to push/pull.

**HIC**

The HIC (Harness Interface Connectors) connects the cockpit instruments and maintenance ports with the engine.

**Graphic**

Connector

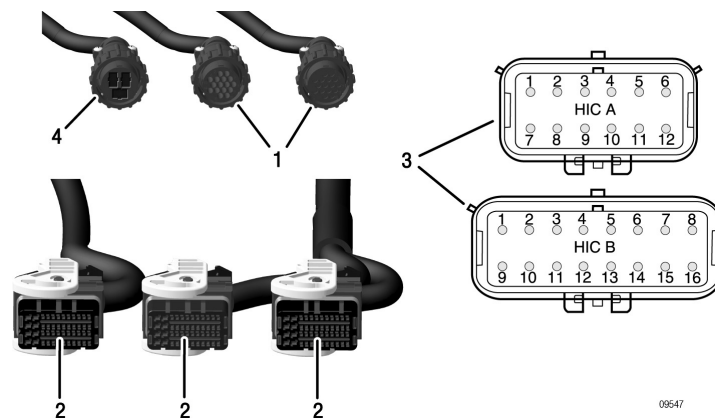

Part	Function
1	FUSE BOX X1 (LANE A), X2 (LANE B)
2	ECU connector A1, A2, B
3	Harness Interface Connector A, B
4	FUSE BOX X3

*Fig. 9*

d05781.fm

**BRP-Powertrain**  
INSTALLATION MANUAL

### 5.1) Fitting the Faston connector to the Harness Interface Connector

**General note** See Fig. 10.

**NOTE:** Faston connectors (1) are supplied loose. The Faston connectors and connector receptacles for the airframe are included in the scope of delivery.

**Special tools** The following special tools and equipment are necessary for fitting the Faston connector.

Part number	Description
n.a.	MOLEX Crimping crap 64016-0035/63811-4400
n.a.	MOLEX Disassembly tool 63813-1500

**Procedure** Fitting the Faston connector

Step	Procedure
1	Strip cable (2) as required (A).
2	Use suitable crimping crap (3) to fit the Faston connector (B).
3	Press down white integral terminal position assurance (TPA) with needle nose pliers until audible click is heard.
4	Push the Faston connector in the corresponding slot (4) of the Harness Interface Connector receptacle until it is locked in place (C).
5	Check for tight fit.

**NOTE:** The TPA pin holder must not be pressed pushed with excessive force.

**BRP-Powertrain**  
INSTALLATION MANUAL

Graphic

Fitting the Faston connector

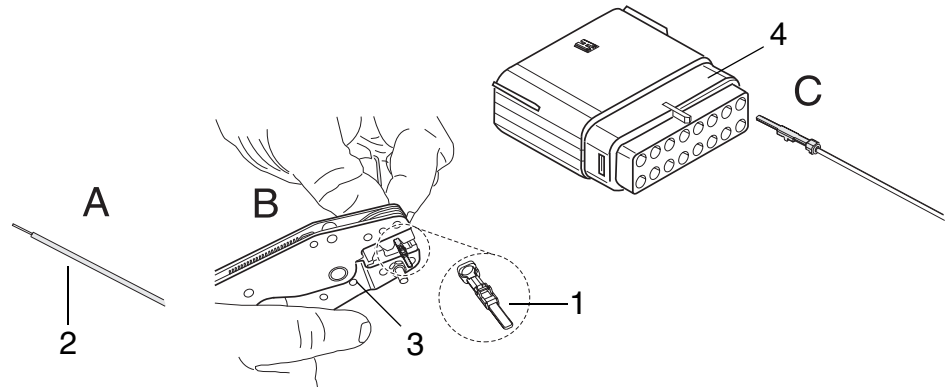

Part	Function
1	Faston connector
2	Wiring (airframe)
3	Crimping crap
4	Harness Interface Connector

Fig. 10

06334

**Harness Inter-  
face Connector**

Pin assignment

PIN No.	Pin assignment	
	HIC A	HIC B
1	LANE_SEL_SW_A_1	LANE_SEL_SW_B_1
2	SUPP_WARN_LAMP_A	SUPP_WARN_LAMP_B
3	SIG_FUEL_PUMP_1	SIG_FUEL_PUMP_2
4	CAN_GND_1_A	CONN_STARTER_REL_SW
5	CAN_LOW_1_A	-
6	CAN_HIGH_1_A	CAN_GND_1_B
7	LANE_SEL_SW_A_2	CAN_LOW_1_B
8	WARN_LAMP_A	CAN_HIGH_1_B
9	GND_FUEL_PUMP_1	LANE_SEL_SW_B_2
10	CAN_GND_2_A <sup>1</sup>	WARN_LAMP_B
11	CAN_LOW_2_A <sup>1</sup>	GND_FUEL_PUMP_2
12	CAN_HIGH_2_A <sup>1</sup>	SUPP_START_SWITCH
13	-	-
14	-	CAN_GND_2_B <sup>2</sup>
15	-	CAN_LOW_2_B <sup>2</sup>
16	-	CAN_HIGH_2_B <sup>2</sup>

<sup>1</sup>Maintenance Port LANE A

<sup>2</sup>Maintenance Port LANE B

d05781.fm

**BRP-Powertrain**  
 INSTALLATION MANUAL

**Graphic**      **Harness Interface Connector (HIC)**

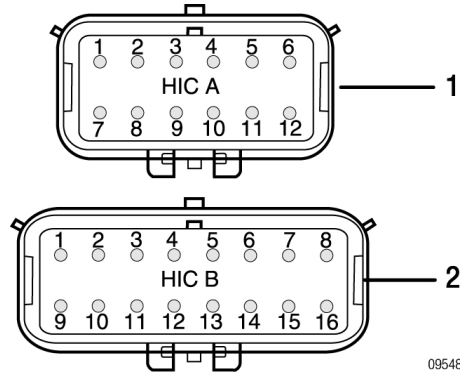

Part	Function
1	HIC A-pin 1 to 12
2	HIC B-pin 1 to 16

*Fig. 11*



**BRP-Powertrain**  
INSTALLATION MANUAL

**5.2) Switch and warning lamp requirements**

Requirements See following table.

LANE SELECT SWITCH A	Requirement	Connector/slot
Switch type	Toggle-SPST	HIC A
Nominal voltage	28 VDC	
Nominal current	7.5 A	
Number of poles	1-pole	
Designation on wiring harness	LANE_SEL_SW_A_1	1
	LANE_SEL_SW_A_2	7

LANE SELECT SWITCH B	Requirement	Connector/slot
Switch type	Toggle-SPST	HIC B
Nominal voltage	28 VDC	
Nominal current	7.5 A	
Number of poles	1-pole	
Designation on wiring harness	LANE_SEL_SW_B_1	1
	LANE_SEL_SW_B_2	9

BACKUP BATTERY SWITCH	Requirement	Connector/slot
Switch type	Toggle (but with mechanical interlock to prevent switch on during standard operation).	FUSE BOX Battery (+)
Nominal voltage	28 VDC	
Nominal current	20 A	
Number of poles	2-pole	
Designation on wiring harness	Not connected to the wiring harness.	
FUSE BOX	Must be installed by the aircraft manufacturer.	

FUEL PUMP SWITCH 1	Requirement	Connector/slot
Switch type	Toggle-SPST	HIC A
Nominal voltage	28 VDC	
Nominal current	10 A	
Number of poles	1-pole	
Designation on wiring harness	SIG_FUEL_PUMP_1	3
	GND_FUEL_PUMP_1	9

d05781.fm

**BRP-Powertrain**  
INSTALLATION MANUAL

<b>FUEL PUMP SWITCH 2</b>	<b>Requirement</b>	<b>Connector/slot</b>
Switch type	Toggle-SPST	HIC B
Nominal voltage	28 VDC	
Nominal current	10 A	
Number of poles	1-pole	
Designation on wiring harness	-SIG_FUEL_PUMP_2	3
	+SUB_FUEL_PUMP_2	11

<b>START POWER SWITCH</b>	<b>Requirement</b>	<b>Connector/slot</b>
Switch type	Toggle (momentary) DPST (m)	
Nominal voltage	28 VDC	
Nominal current	20 A	
Number of poles	2-pole	
Designation on wiring harness	Not connected to the wiring harness.	

External alternator (optional)

<b>EXTERNAL ALTERNATOR SWITCH</b>	<b>Requirement</b>	<b>Connector/slot</b>
Switch type	Toggle (momentary) SPST (m)	
Nominal voltage	28 VDC	
Nominal current	5 A	
Number of poles	1-pole	
Designation on wiring harness	Not connected to the wiring harness.	

<b>WARNING LAMP A</b>	<b>Requirement</b>	<b>Connector/slot</b>
Lamp colour	In accordance with the regulations	HIC A
Nominal voltage	12 V	
Nominal current	Maximum 120 mA	
Designation on wiring harness	SUPP_WARN_LAMP_A	2
	WARN_LAMP_A	8

<b>WARNING LAMP B</b>	<b>Requirement</b>	<b>Connector/slot</b>
Lamp colour	In accordance with the regulations	HIC B
Nominal voltage	12 V	
Nominal current	Maximum 120 mA	
Designation on wiring harness	SUPP_WARN_LAMP_B	2
	WARN_LAMP_B	10

d05781.fm

# BRP-Powertrain

## INSTALLATION MANUAL

### Optional

#### External alternator indicator lamp

EXTERNAL ALTERNATOR INDICATOR LAMP	Requirement	Connector/slot
Lamp colour	In accordance with the regulations	
Nominal voltage	12 V	
Nominal current	Maximum 300 mA	
Designation on wiring harness	Not connected to the wiring harness.	

#### NOTICE

If using LED they will always glow, even with no alarm or warning shown!

Remedy: The use of 2 resistores as shown on page 34.

START SWITCH*	Requirement	Connector/slot
Switch type	Push button	HIC B
Nominal voltage	28 VDC	
Nominal current	5 A	
Number of poles	1-pole	
Designation on wiring harness	CONN_STARTER_REL_SW	4
	SUPP_START_SWITCH	12

\* optionally a key switch can be used.

### 5.3) TIPS: Wiring Powerside (optional)

**Tip** This design allows a simplification of the starting process. Instead of using the “Start Power Switch“ and the “start button“ at the same time the engine can be started by turning a key switch. In addition, the key switch takes over the control of a master relay.

**NOTE:** It is not allowed to install the „Start Power Switch“ and the „Start button“ with a single switch. This may only be switched in parallel and at the same time.

**Tip** The pilot display takes over the control of the start power relay. If the display is turned ON, for example in case of a complete restart of the aircraft, the start power relay closes. If the key switch is actuated (engine start) and put into the third position, the engine starts. Due to the spring return position of the key switch, it falls back to the second switching position (ON). As soon as the engine has reached a defined and displayed speed (1500 r.p.m.) to the pilot display, the relay opens. The start power relay still stays open for security reasons until restart of the display.

**Tip**

**NOTICE** LANE Select Switch A and LANE Select Switch B also Fuel Pump Switch A and Fuel Pump Switch B in this connection type must be a toggle switch.

Performance of the key switch and operation of the relays.

Position of the key switch	0	1	2
Pins		Master relay Airframe Ground	HIC B Pin 4 HIC B Pin 12
Aircraft/Engine Status	Off	On	Engine Start
Master Relay	Open	Closed	Closed

d05781.fm

# BRP-Powertrain

## INSTALLATION MANUAL

Performance of the key switch and operation of the relays.

Position of the key switch	0	1	2
Start Power Relay	Open	Closed	Closed (will open as soon as speed > 1500 r.p.m.. Can only be opened once. The correct sequence is controlled by the pilot display)
Locking	Yes	Yes	Spring return (to Pos. 1)

### Tip

**NOTE:** The interconnection with a display of the manufacturer Stock Flight Systems ([www.stockflightsystems.com/www.rs-aerotech.com](http://www.stockflightsystems.com/www.rs-aerotech.com)) was shown. This functionality is not supported by all displays on the market. The responsibility for proper selection and installation of such displays is up to the aircraft manufacturer.

**NOTE:** The installation and specification of the Start Power Display depends on the pilot display output. The responsibility of the specification and interconnection of the relay is up to the display manufacturer.

### Tip

Specification of the additional components (additional to chapter 5.2)

MASTER RELAY (optional)	Requirement	Connector/slot
Switch type	Relay - continuous duty	
Nominal voltage	28 VDC	
Nominal current	Tbd from aircraft manufacturer	
Min. control voltage	Min. 6 V; Max. 18 V	
Number of poles	SPST NO (normally open)	
Designation on wiring harness	Not connected to the wiring harness.	

**BRP-Powertrain**  
INSTALLATION MANUAL

**Tip**

**Start Power Relay (Option 2)**

<b>START POWER RELAY (optional)</b>	<b>Requirement</b>	<b>Connector/slot</b>
Switch type	Relay	
Nominal voltage	28 VDC	
Nominal current	20 A	
Min. control voltage	Tbd from aircraft manufacturer	
Number of poles	2 Polic NO (normally open)	
Designation on wiring harness	Not connected to the wiring harness.	

**Key Switch (Option 2)**

<b>KEY SWITCH (optional)</b>	<b>Requirement</b>	<b>Connector/slot</b>
Switch type	Off/ON	
Nominal voltage	28 VDC	
Nominal current	5 A	
Number of poles	2-pin	
Designation on wiring harness	Not connected to the wiring harness.	

d05781.fm

# BRP-Powertrain

## INSTALLATION MANUAL

### 5.4) Wiring diagram

**General note** EMS diagram see 24-00-00 page 31.  
 Wiring power side see 24-00-00 page 32.  
 Wiring HIC connector and warning lamps see 24-00-00 page 34.

**Cable cross-section** In general, the cable cross-sections have to correspond to the EMS diagram.

**Deviations** For deviations from the recommended cross-sections the aircraft manufacturer is responsible.  
 The minimum cable cross-section from the battery to the starter relay and from there to the electric starter and for the ground line (start system) depends on the cable length "l" (= Sum of the supply line and ground line of the electric starter) and has to be calculated according to the following table.

l [m]	l [ft]	A <sub>min.</sub> [mm <sup>2</sup> ]	A <sub>min.</sub> [in <sup>2</sup> ]	A <sub>max.</sub> [mm <sup>2</sup> ]	A <sub>max.</sub> [in <sup>2</sup> ]	AWG <sub>min.</sub>
<4	<13	20.408	0.031	25	0.039	4
4<l<4.5	13<l<14.8	22.959	0.036	35	0.054	3
4.5<l<5	14.8<l<16.4	25.51	0.04	35	0.054	3
5<l<5.5	16.4<l<18	28.061	0.043	35	0.054	2
5.5<l<6	18<l<19.7	30.612	0.047	35	0.054	2
6<l<6.5	19.7<l<21.3	33.163	0.051	35	0.054	2
6.5<l<7	21.3<l<23	35.714	0.055	50	0.078	1
7<l<7.5	23<l<24.6	38.265	0.059	50	0.078	1
7.5<l<8	24.6<l<26.2	40.816	0.063	50	0.078	1
8<l<8.5	26.2<l<27.9	43.367	0.067	70	0.109	0
8.5<l<9	27.9<l<29.5	45.918	0.071	70	0.109	0
9<l<9.5	29.5<l<31.2	48.469	0.075	70	0.109	0
9.5<l<10	31.2<l<32.8	51.02	0.079	70	0.109	0

The internal resistance of the battery and the resistance of the electrical system (wires, contact points, relay contacts) largely determine the performance of the starting system. Therefore, the total loop resistance (R<sub>Smax</sub>) may not exceed 0.015 Ω.

$$R_{Smax} = \sum R = R_{iBatt} + R_{C \text{ Starter relay}} + R_L + R_{Other}$$

d05781.fm

**BRP-Powertrain**  
INSTALLATION MANUAL

**Legend**

$R_{iBatt}$	Internal resistance battery
$R_{CStarter\ relay}$	Contact resistance starter relay
$R_L$	Line resistance
$R_{Other}$	Any other resistors (e.g. Master relays, contact resistance)

**Scope of delivery**

**NOTICE**

Items/components which are not included in the standard engine scope of delivery must be certified the aircraft or fuselage manufacturer in accordance with the latest regulations, such as FAR or EASA.

**Graphic**

EMS Wiring diagram. See also Page [31](#).  
Wiring power side. See also [32](#).  
Wiring power side (optional). See also [33](#).  
Wiring HIC Switch and warning lamp. See also [34](#).





**ROTAX**  
AIRCRAFT ENGINES

- 912 IS wiring harness
- Optional (not required)
- Airframe Ground
- EMS ground

- AWG 04 (21,1 mm<sup>2</sup>)
- AWG 12 (3,3 mm<sup>2</sup>)
- AWG 16 (1,50 mm<sup>2</sup>)
- AWG 18 (1,00 mm<sup>2</sup>)
- AWG 20 (0,75 mm<sup>2</sup>)

For a larger view see chapter 76-00-00 page 14

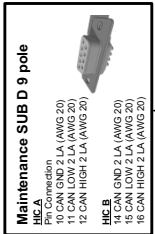
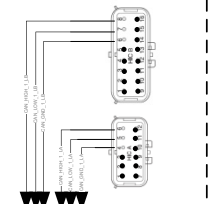

**Maintenance SUB D 9 pole**  
Pin Connection  
HIC A  
10 CAN\_GND\_2 LA (AWG 20)  
11 CAN\_HIW\_1 LA (AWG 20)  
12 CAN\_HIGH\_2 LA (AWG 20)  
HIC B  
15 CAN\_LOW\_2 LA (AWG 20)  
16 CAN\_HIGH\_2 LA (AWG 20)

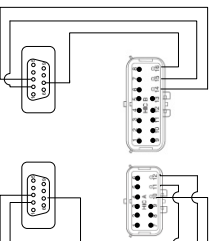

- Switches / Schalter**  
**Warning Lamp / Warnlampen**
- HIC A**  
1 LANE\_SEL\_SW\_A\_1 (AWG 18)  
2 SUPP\_WARN\_LAMP\_1 (AWG 18)  
3 SIG\_FUEL\_PUMP\_1 (AWG 18)  
4 CONN\_STARTER\_REL\_SW (AWG 18)  
5 WARN\_LAMP\_A (AWG 18)  
6 GND\_FUEL\_PUMP\_1 (AWG 18)
- HIC B**  
1 LANE\_SEL\_SW\_B\_1 (AWG 18)  
2 SUPP\_WARN\_LAMP\_2 (AWG 18)  
3 SIG\_FUEL\_PUMP\_2 (AWG 18)  
4 CONN\_STARTER\_REL\_SW (AWG 18)  
5 WARN\_LAMP\_B (AWG 18)  
6 GND\_FUEL\_PUMP\_2 (AWG 18)  
7 SUPP\_START\_SWITCH (AWG 18)

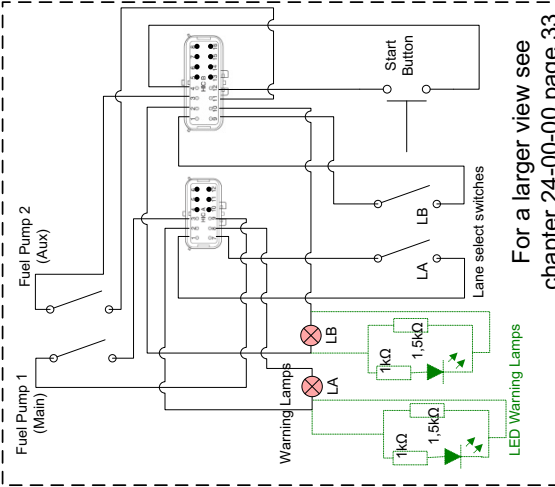
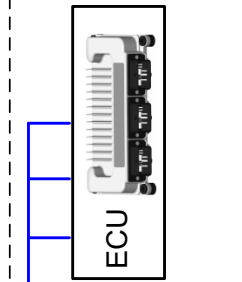
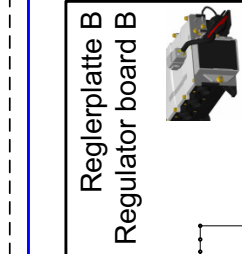
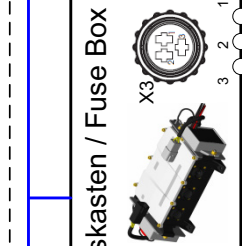
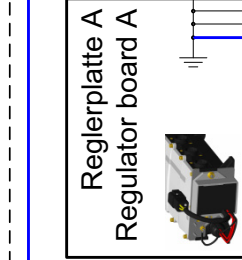
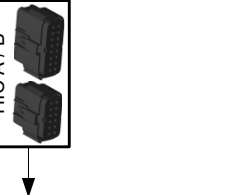

For a larger view see chapter 24-00-00 page 33

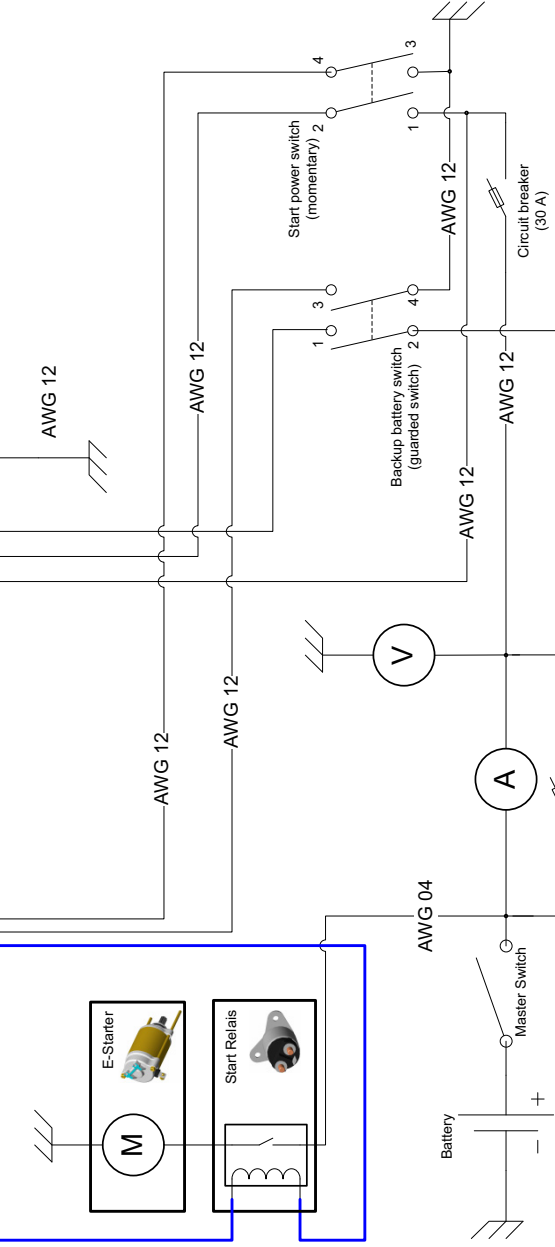

For a larger view see chapter 24-00-00 page 31



**ROTAX**  
AIRCRAFT ENGINES

912 iS wiring harness  
Optional (not required)  
Airframe Ground  
EMS ground

AWG 04 (21,1 mm<sup>2</sup>) —  
AWG 12 (3,3 mm<sup>2</sup>) - - -  
AWG 16 (1,50 mm<sup>2</sup>) ↗  
AWG 18 (1,00 mm<sup>2</sup>) ↘  
AWG 20 (0,75 mm<sup>2</sup>) ⊥

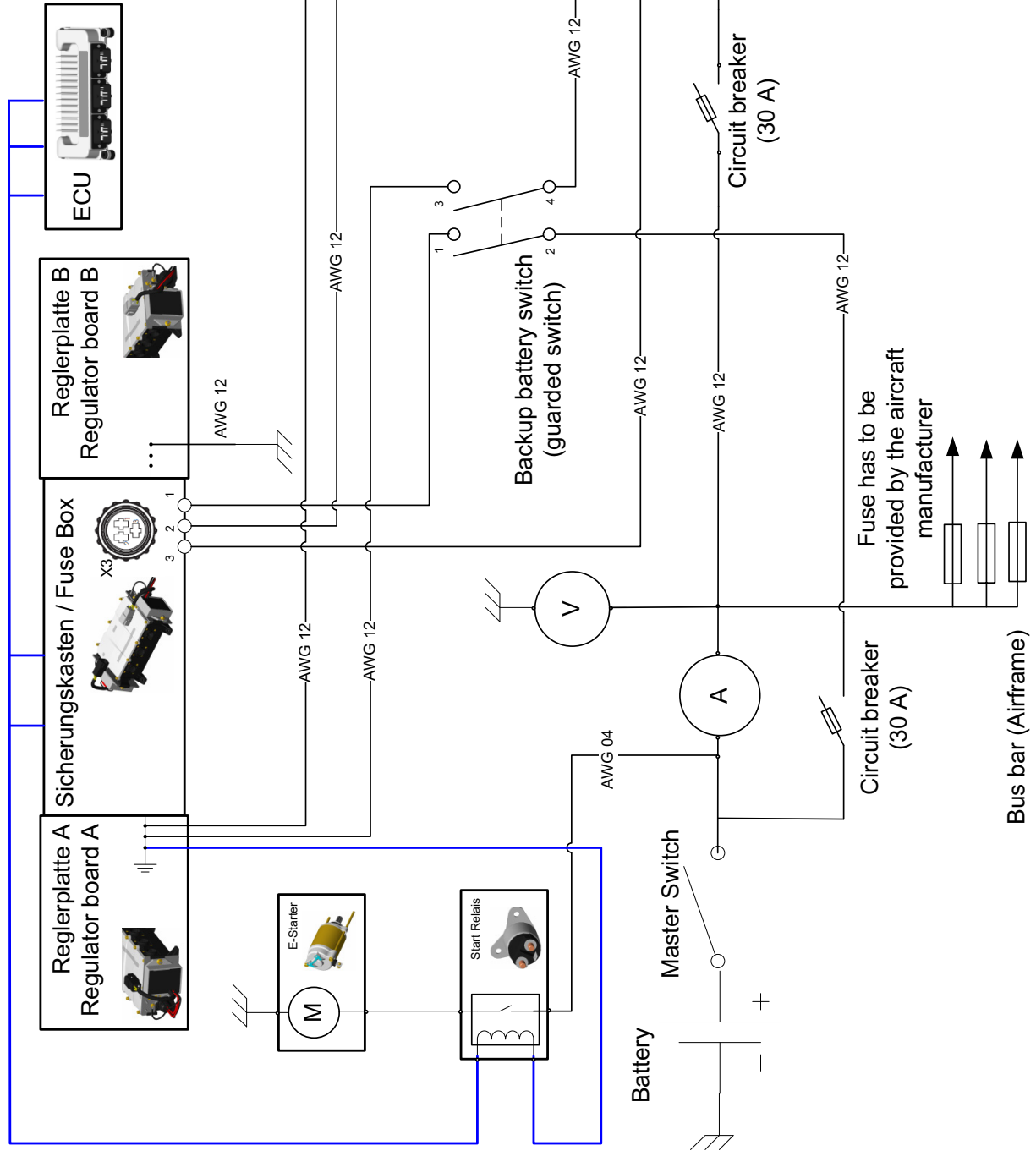

08251

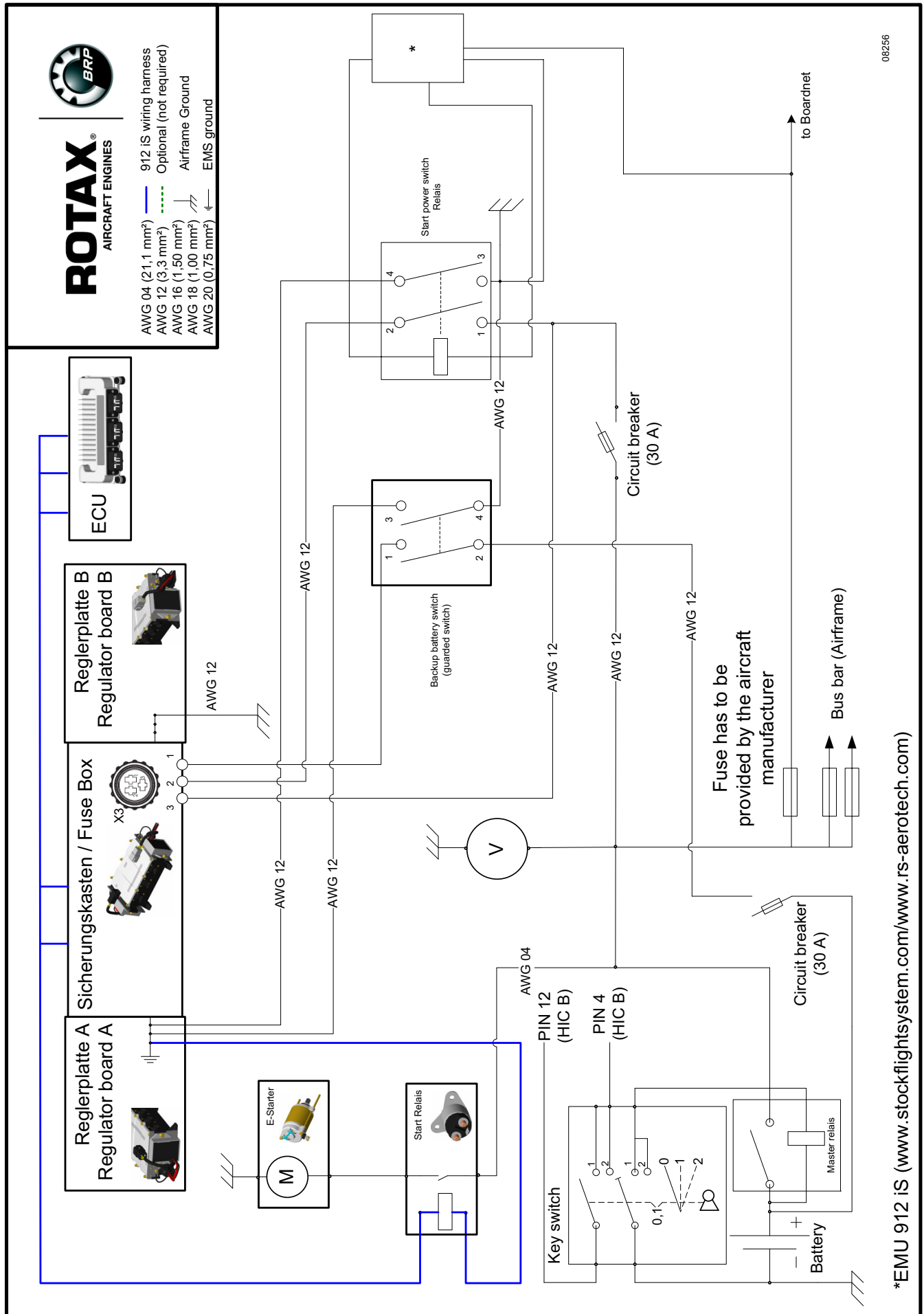

06256

\*EMU 912 iS (www.stockflightssystem.com/www.rs-aerotech.com)



**ROTAX**  
AIRCRAFT ENGINES

912 iS wiring harness  
Optional (not required)  
Airframe Ground  
EMS ground

AWG 14 (2,50 mm<sup>2</sup>) ———  
AWG 16 (1,50 mm<sup>2</sup>) - - - -  
AWG 18 (1,00 mm<sup>2</sup>) ·····  
AWG 20 (0,75 mm<sup>2</sup>) / / / /

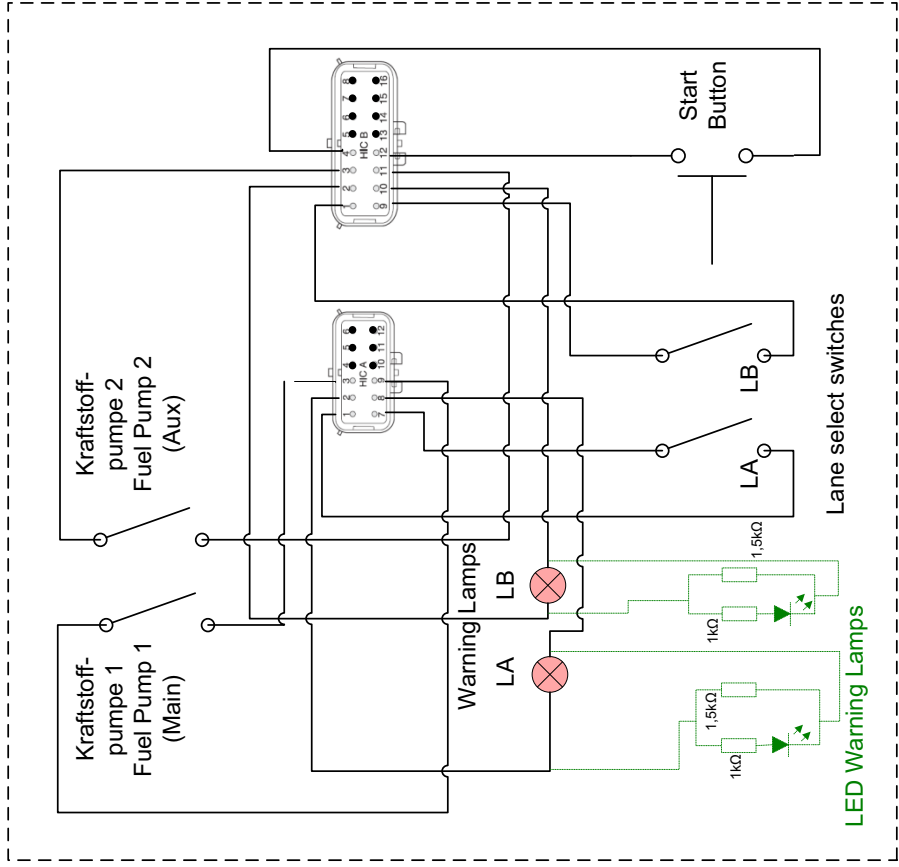

- Schalter / Switches**
- Warnlampen / Warning Lamps**
- HIC A**
- 1 LANE\_SEL\_SW\_A\_1 (AWG 16)
  - 2 SUPP\_WARN\_LAMP\_A (AWG 18)
  - 3 SIG\_FUEL\_PUMP\_1 (AWG 16)
  - 7 LANE\_SEL\_SW\_A\_2 (AWG 16)
  - 8 WARN\_LAMP\_A (AWG 18)
  - 9 GND\_FUEL\_PUMP\_1 (AWG 16)
- HIC B**
- 1 LANE\_SEL\_SW\_B\_1 (AWG 16)
  - 2 SUPP\_WARN\_LAMP\_B (AWG 18)
  - 3 SIG\_FUEL\_PUMP\_2 (AWG 16)
  - 4 CONN\_STARTER\_REL\_SW (AWG 18)
  - 9 LANE\_SEL\_SW\_B\_2 (AWG 16)
  - 10 WARN\_LAMP\_B (AWG 18)
  - 11 GND\_FUEL\_PUMP\_2 (AWG 16)
  - 12 SUPP\_START\_SWITCH (AWG 18)

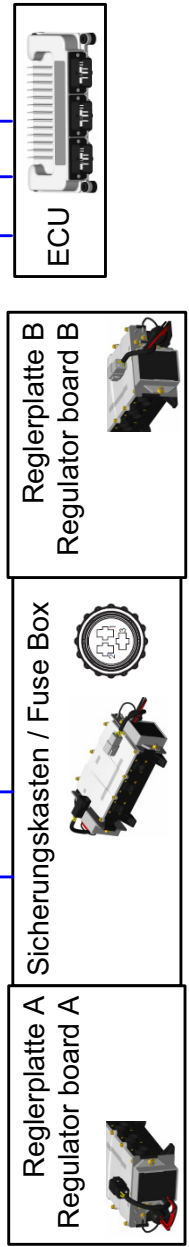
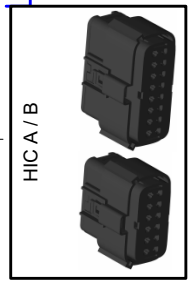

08589

# BRP-Powertrain

## INSTALLATION MANUAL

### 6) Internal power consumers

#### General note



**WARNING**

Non-compliance can result in serious injuries or death!

The current consumption of the remaining consumers is to be limited so as to ensure that power is supplied to the internal consumers (e.g. fuel pumps, ECU etc.) at all times.

The battery and all loads in the aircraft must be dimensioned so, that even if one of the generators fails, a safe flight is ensured.

See the performance diagrams of the internal and external alternators as a function of engine speed.

#### Components

#### Current consumption

Components	Current consumption
Fuel pump (main pump)	min. 10 A
Fuel pump (additional pump)	min. 10 A
ECU	~ 1.2 A
Warning lamp A	max. 120 mA
Warning lamp B	max. 120 mA
FUSE BOX	~ 400 mA

#### NOTE:

A complete analysis of the current consumption of all the fitted consumers is to be carried out by the aircraft or airframe manufacturer.

**BRP-Powertrain**  
INSTALLATION MANUAL

NOTES

d05781.fm

**BRP-Powertrain**  
INSTALLATION MANUAL

**Chapter: 61-00-00**  
**PROPELLER DRIVE**

**Introduction**



Danger of explosion.  
Never operate the engine without propeller as this results in serious engine damage from overspeeding.  
Never fit the propeller directly on the crankshaft.

**Table of contents**

This section of the Installation Manual contains information on the engine propeller component.

<b>Subject</b>	<b>Page</b>
Propeller drive	<a href="#">Page 3</a>
Technical data	<a href="#">Page 3</a>
Operating limits	<a href="#">Page 4</a>
Hydraulic governor for constant speed propeller	<a href="#">Page 5</a>
Technical data for connections	<a href="#">Page 5</a>

**BRP-Powertrain**  
INSTALLATION MANUAL

NOTES



**BRP-Powertrain**  
INSTALLATION MANUAL

## 1) Propeller drive

**General note**      The propeller in tractor or pusher arrangement must be fitted on the propeller flange in accordance with applicable regulations. As required utilize one of the three possible pitch circle diameters (P.C.D) on the flange.

                            The propeller design must be certified in accordance with applicable regulations, such as FAR or EASA, by the aircraft manufacturer.

---

### 1.1) Technical data

**Direction of rotation**      See [Fig. 1](#)  
                                    Direction of rotation of the propeller flange:  
                                    - left, counter clockwise, looking towards face of flange

---

**Graphic**                      Direction of rotation

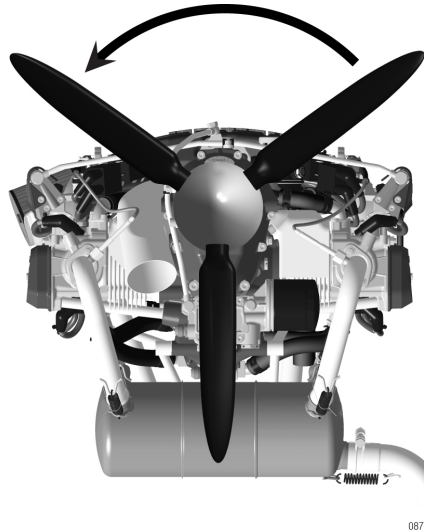

*Fig. 1*

---

**Transmission**              Gear transmission:  
                                    -  $i = 2.4286$  (51 Teeth/21 T)

---

**BRP-Powertrain**  
INSTALLATION MANUAL

**Propeller shaft flange**

See [Fig. 2](#)

Attachment of propeller on prop shaft flange:

Pitch circle diameter 75 mm (2.95 in.)	6x through holes 8 mm (0.31 in.)
Pitch circle diameter 80 mm (3.15 in.)	6x through holes 11.5 mm (0.45 in.)
Pitch circle diameter 101.6 mm (4")	6x through holes 13 mm (0.51 in.)
Hub diameter	47 mm (1.85 in.)

**Graphic**

**Propeller shaft flange**

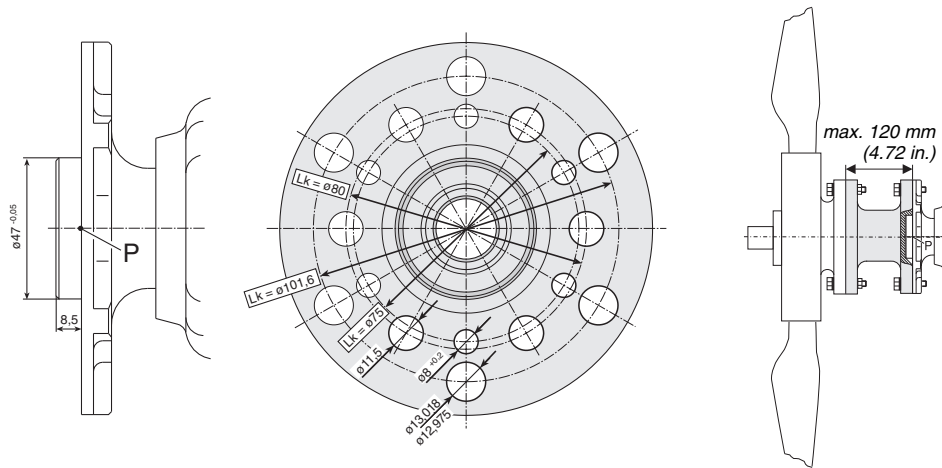

*Fig. 2*

02581, 09193

**1.2) Operating limits**

**Torque**

**NOTICE**

Modification of the propeller shaft is not permitted.

Max. torque:

- 340 Nm (250.77 ft.lb.) (on propeller)

**Max. moment of inertia**

Max. permissible moment of inertia on propeller:

- 6000 kgcm<sup>2</sup> (14.238 lb ft<sup>2</sup>)
- Normal between 1500 kg cm<sup>2</sup> and 6000 kg cm<sup>2</sup> (3.559 lb ft<sup>2</sup> and 14.238 lb/ft<sup>2</sup>)

**Extension of propeller shaft**

- Max. extension of the propeller shaft: 120 mm (4.72 in.)

**Out of balance**

Dynamic balancing of the propeller as specified by the propeller manufacturer must be carried out.

c05782.fm

**BRP-Powertrain**  
INSTALLATION MANUAL

**2) Hydraulic governor for constant speed propeller**

**2.1) Technical data for connections**

**General note** See [Fig. 3](#)

**NOTE:** See also SB-912-052 "Installation/use of governors for ROTAX engine type 912 Series", latest issue.

**Drive** Drive via propeller gearbox.

- Position of the propeller connection (1) on the governor flange.

Point of support	Axes		
	x-axis mm	y-axis mm	z-axis mm
	-206.3 mm (-8.12 in.)	0	51.5 mm (2.03 in.)

**Graphic** Crankcase flange

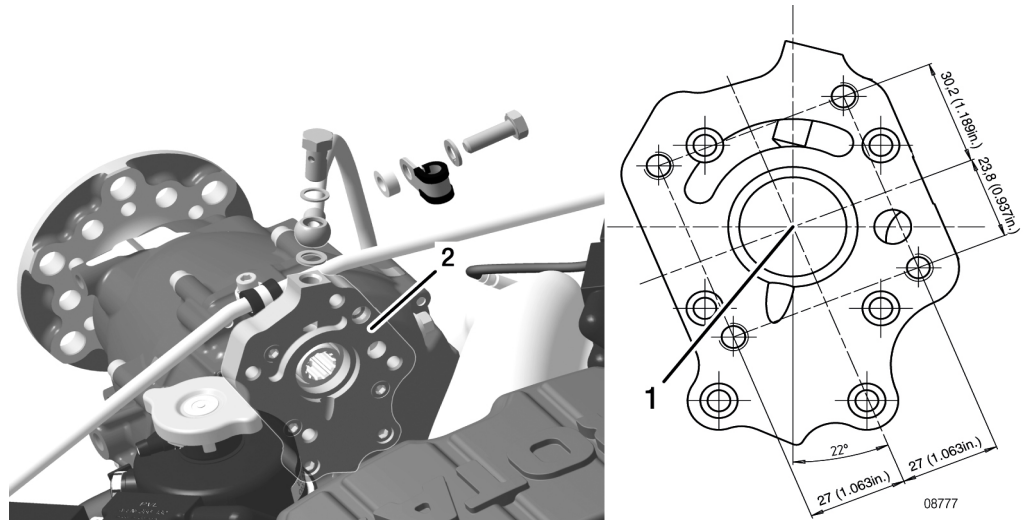

Part	Function
1	Connection for propeller governor
2	Governor flange

*Fig. 3*

d05782.fm

**BRP-Powertrain**  
INSTALLATION MANUAL

**Connection**

**NOTICE**

Pay attention to manufacturers specifications!

**Gear ratio**

NOTE: Gear ratio from crankshaft to hydraulic governor is 1.842, i.e. the propeller governor runs at 0.54 times engine speed.

Mounting pad	AND20010
Thread	M8
Thread length	Max. 14 mm (0.55 in.)
Governor drive	Internal spline 20/40 SMS 1834 NA 14x1.27x30x12
Power consumption	Max. 600 W
Operating pressure	Max. 30 bar (435 psi)

**BRP-Powertrain**  
INSTALLATION MANUAL

**Chapter: 72-00-00**

**ENGINE**

**Introduction**

**NOTICE**

Certification in accordance with the latest regulations, such as FAR or EASA, must be carried out by the aircraft or fuselage manufacturer.

**Table of contents**

This section of the Installation Manual contains views of the aircraft engine, technical data and installation dimensions of the engine.

Subject	Page
Engine components, engine views, cylinder designation	<a href="#">Page 3</a>
Side view	<a href="#">Page 3</a>
Front view	<a href="#">Page 4</a>
Top view, rear view	<a href="#">Page 5</a>
Technical data	<a href="#">Page 7</a>
Weight	<a href="#">Page 7</a>
Installation dimensions	<a href="#">Page 8</a>
Centre of gravity of engine and standard accessories	<a href="#">Page 8</a>
Moments of inertia	<a href="#">Page 8</a>
Operating limits	<a href="#">Page 9</a>
Deviation from the apparent perpendicular	<a href="#">Page 9</a>
Crankshaft drive	<a href="#">Page 11</a>

**BRP-Powertrain**  
INSTALLATION MANUAL

Overview

Engine

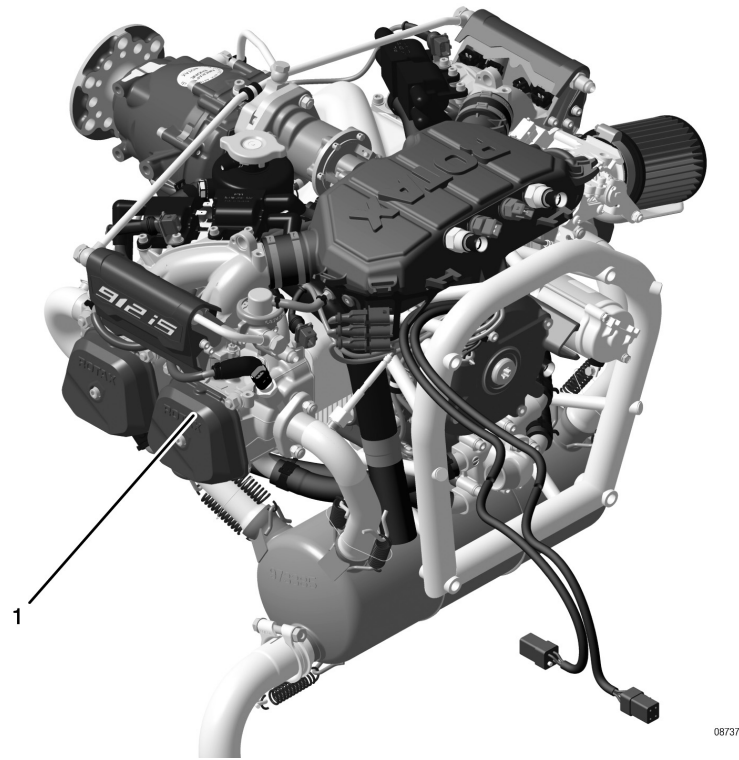

Part	Function
1	Engine Type 912 i Series

*Fig. 1*

---

**BRP-Powertrain**  
INSTALLATION MANUAL

**1) Engine components, engine views, cylinder designation**

General note See Fig. 2 to Fig. 4

**PTO** power take off side

**MS** magneto side

**A** points of attachment (for engine transport) - centre of gravity

**P** zero reference point for all dimensions

NOTE: Allow  $\pm 1$  mm on all stated dimensions as manufacturing tolerance.

**x, y, z** axes for system of coordinates

**Cyl. 1** Cylinder 1    **Cyl. 3** Cylinder 3

**Cyl. 2** Cylinder 2    **Cyl. 4** Cylinder 4

**Side view**

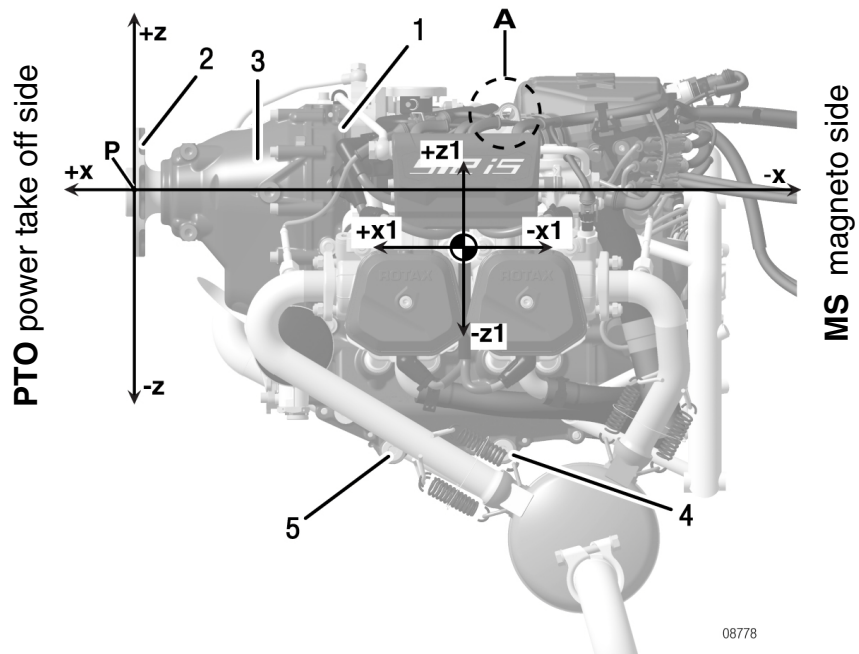

Part	Function
1	Engine number
2	Propeller flange
3	Propeller gearbox
4	Connection for return line (tractor)
5	Connection for return line (pusher)

*Fig. 2*

d05783.fm

# BRP-Powertrain

## INSTALLATION MANUAL

Front view

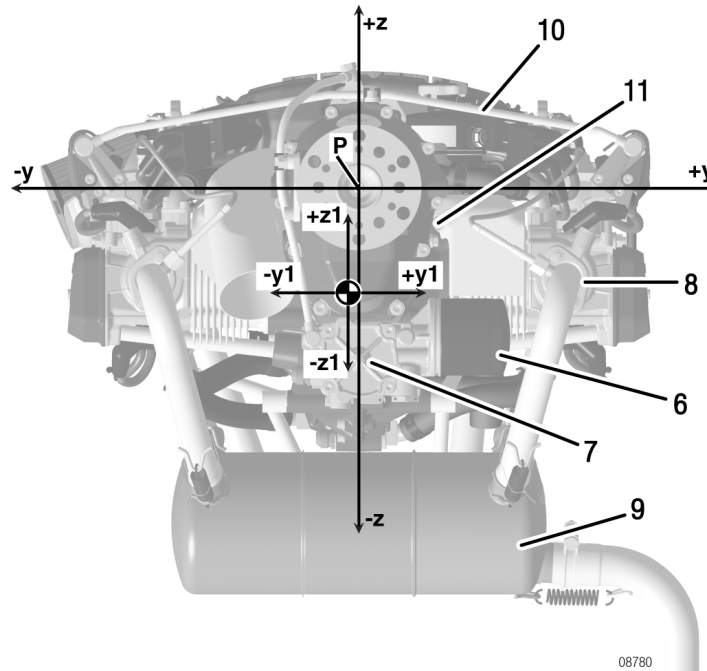

Part	Function
6	Oil filter
7	Oil pump
8	Exhaust flange
9	Muffler assy.
10	Fuel hose assy.
11	Crankshaft locking screw position

*Fig. 3*

08780



**BRP-Powertrain**  
INSTALLATION MANUAL

Top view, rear view

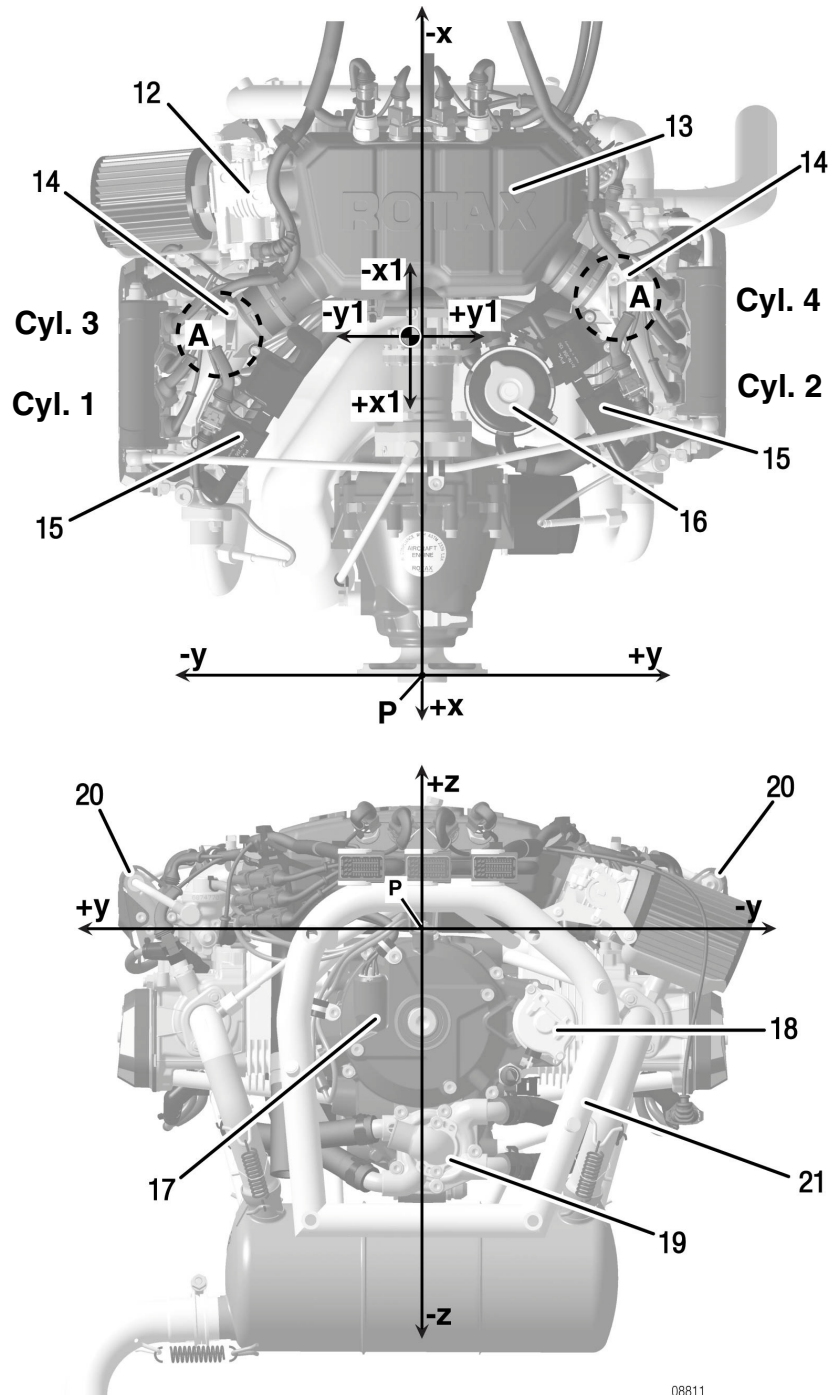

d05783.fm

**BRP-Powertrain**  
INSTALLATION MANUAL

<b>Part</b>	<b>Function</b>
12	Throttle valve support assy.
13	Airbox
14	Suspension points
15	Dual ignition coils
16	Expansion tank assy.
17	Ignition housing
18	Electric starter
19	Water pump housing
20	Fuel rail (right, left)
21	Engine suspension frame (ring mount)

*Fig. 4*

---

d05783.fm

**BRP-Powertrain**  
INSTALLATION MANUAL

## 2) Technical data

**General note** To maintain clarity, only data relevant for engine installation and operation will be stated in the Manual.

**NOTE:** Connecting sizes, capacities, gear and reduction ratios, electric power, permissible temperatures, etc. can be found in the respective section of engine installation or other relevant engine type documentation.

---

### 2.1) Weight

**General note** The engine weight is defined by the following conditions:

- incl. oil tank
- incl. electrical system: wiring harness, ECU, FUSE BOX, starter relay

---

**Version** Overview

Version	Weight
912 iSc/iS	63,6 kg (140.21 lb)

---

**Accessories** Overview

Accessories	Weight	spare part	optional*
Engine suspension frame	2.0 kg (4.41 lb)	X	X
Exhaust system	4.7 kg (10.36 lb)	X	X
Fuel pumps assy.	1.6 kg (3.53 lb)	X	
Cooling air baffle	0.36 kg (0.79 lb)	X	X
External alternator	3.0 kg (6.61 lb)	X	
Radiator	1.0 kg (2.2 lb)	X	
Air filter	0.15 kg (0.33 lb)	X	
Oil cooler	0.6 kg (1.32 lb)	X	

\* Can be installed original to the engine at the factory (also available as a spare part).

---

**BRP-Powertrain**  
INSTALLATION MANUAL

**2.2) Installation dimensions**

Standard engine version

See Fig. 2 to Fig. 4.

NOTE: All dimensions from zero reference point (P).

	Standard engine version		
	Pos. (+)	Neg. (-)	Total
Max. dimension along x-axis (mm)	8.5 (0.33 in.)	-656.6 (-25.85 in.)	665.1 (26.19 in.)
Max. dimension along y-axis (mm)	288 (11.34 in.)	-288 (-11.34 in.)	576 (22.68 in.)
Max. dimension along z-axis (mm)	247 (9.73 in.)	-311 (-12.24 in.)	531 (20.91 in.)

**2.3) Centre of gravity of engine and standard accessories**

See Fig. 2 to Fig. 4.

NOTE: All dimensions from zero reference point (P).

	Standard engine version 3	External alternator	Hydraulic governor
Centre of gravity on x-axis (mm)	-327 (-12.87 in.)	-100 (-3.94 in.)	-276 (-10.87 in.)
Centre of gravity on y-axis (mm)	-9 (-0.35 in.)	139 (5.47 in.)	0
Centre of gravity on z-axis (mm)	-102 (-4.02 in.)	6 (0.24 in.)	56 (2.20 in.)

**2.4) Moments of inertia**

See Fig. 2 to Fig. 4.

	Engine version 2	Engine version 3
Moment of inertia around axis x1-x1 (kg cm <sup>2</sup> )	20470 (48.576 lb ft <sup>2</sup> )	21210 (50.332 lb ft <sup>2</sup> )
Moment of inertia around axis y1-y1 (kg cm <sup>2</sup> )	24560 (58.282 lb ft <sup>2</sup> )	25450 (60.394 lb ft <sup>2</sup> )
Moment of inertia around axis z1-z1 (kg cm <sup>2</sup> )	26520 (62.933 lb ft <sup>2</sup> )	27480 (65.211 lb ft <sup>2</sup> )

d05783.fm

**BRP-Powertrain**  
INSTALLATION MANUAL

### 3) Operating limits

Manual                      Documentation overview

Operating limits	Manual
<b>Engine speed</b>	See OM 912 iSc/iS section 2.1
<b>Acceleration</b>	See OM 912 iSc/iS section 2.1
<b>Oil pressure</b>	See OM 912 iSc/iS section 2.1
<b>Oil temperature</b>	See OM 912 iSc/iS section 2.1
<b>Coolant temperature</b>	See OM 912 iSc/iS section 2.1
<b>Ambient temperature for start up</b>	See OM 912 iSc/iS section 2.1
<b>Fuel pressure</b>	See OM 912 iSc/iS section 2.1
<b>Governor</b>	See OM 912 iSc/iS section 2.1
<b>External alternator</b>	See OM 912 iSc/iS section 2.1
<b>Deviation from the apparent perpendicular</b>	See OM 912 iSc/iS section 2.1
<b>Exhaust gas temperature</b>	See OM 912 iSc/iS section 2.1

#### 3.1) Deviation from the apparent perpendicular

<b>General note</b>	<p>See <a href="#">Fig. 5</a>.</p> <p>The engine design is for a conventional, non-aerobatic, tractor or pusher configuration with the oil return port in the optimum position. Assuming these points are taken into consideration, the engine will be properly lubricated in all flight profiles.</p>
<b>Bank angle</b>	<p>The resulting bank angle <math>\beta</math> (depending on acceleration/deceleration) may never exceed the max. bank angle.</p> <p>NOTE:                      Pitch or roll angle <math>\alpha</math> is not equal with <math>\beta</math>, except stabilized condition (without acceleration).</p>

d05783.fm

**BRP-Powertrain**  
INSTALLATION MANUAL

Graphic

Bank angle

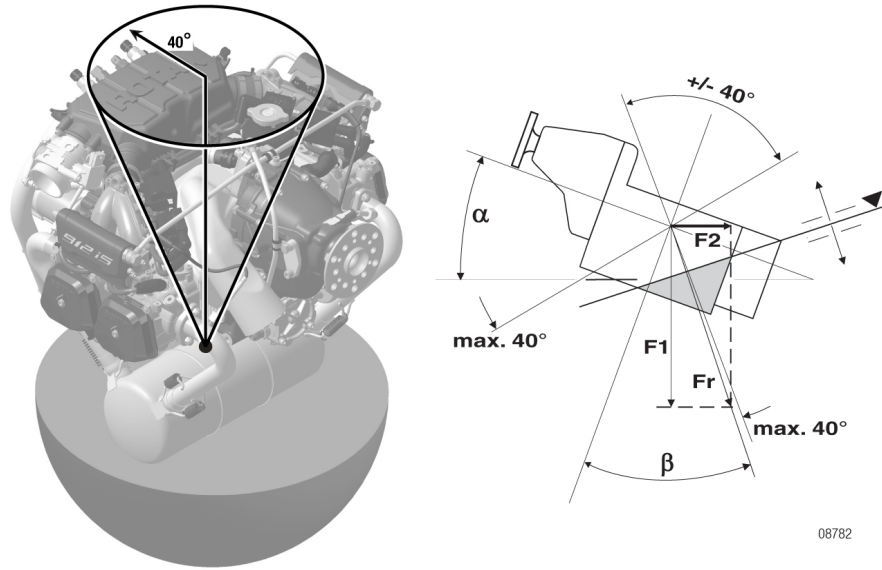

$\alpha$	Bank or rotation	<b>F1</b>	Gravity
$\beta$	Bank angle	<b>F2</b>	Acceleration
		<b>Fr</b>	Result of F1 and F2

*Fig. 5*

d05783.fm

**BRP-Powertrain**  
INSTALLATION MANUAL

**3.2) Crankshaft drive**

See [Fig. 6](#) to [Fig. 7](#).

Max. moment of inertia 15 kg cm<sup>2</sup> (0.036 lb ft<sup>2</sup>).

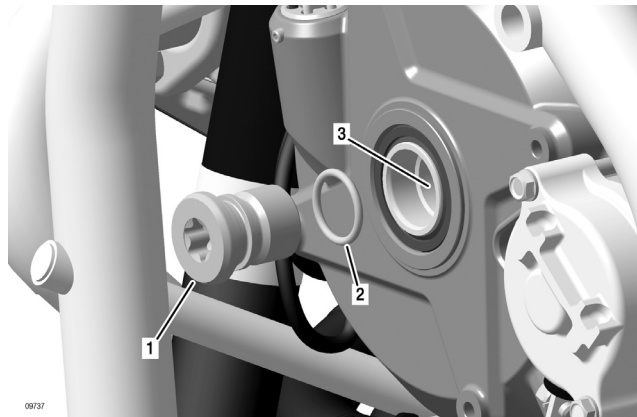

Part	Function
1	Plug screw M22x1,5
2	O-Ring 18x2.5
3	Support bearing

Crankshaft

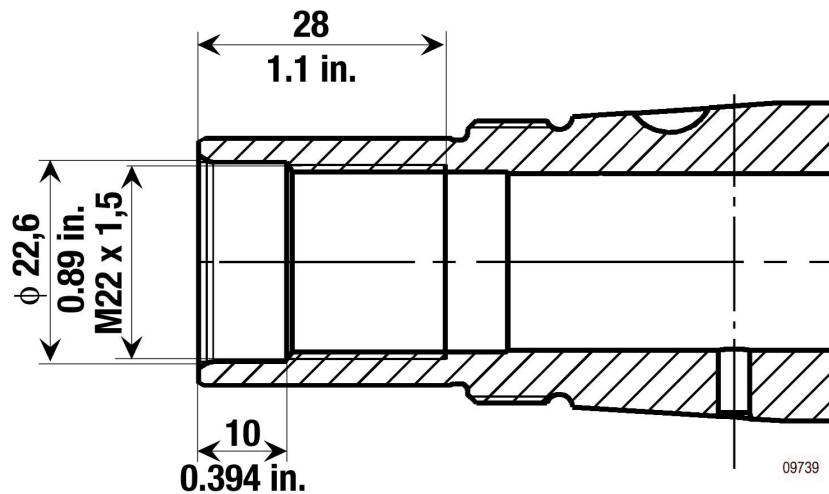

*Fig. 6*

d05783.fm

**BRP-Powertrain**  
INSTALLATION MANUAL

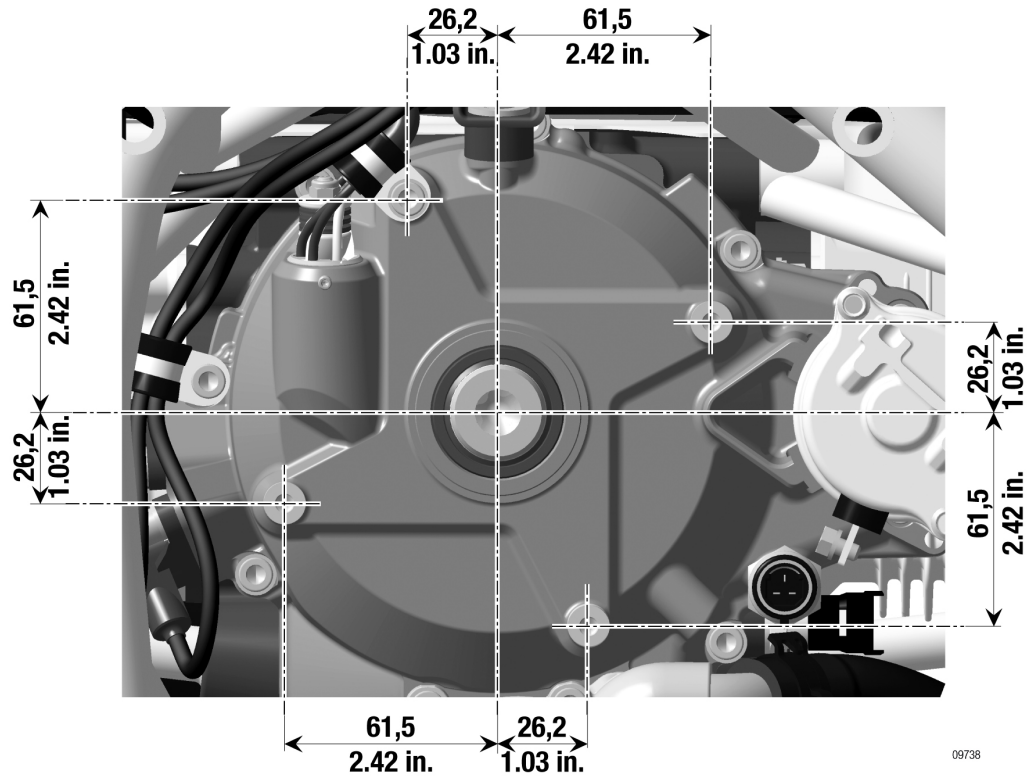

*Fig. 7*

d05783.fm



**BRP-Powertrain**  
INSTALLATION MANUAL

**Chapter: 73-00-00**  
**FUEL SYSTEM**

**Table of contents**

This section of the Installation Manual contains information on the aircraft engine fuel system.

Subject	Page
Requirements of the fuel system	Page 5
Operating limits	Page 5
Fuel temperature	Page 5
Fuel pressure indicator	Page 5
Fuel lines	Page 6
Coarse filter	Page 8
Water trap	Page 8
Fine filter	Page 8
GENUINE- ROTAX fuel pump assy.	Page 8
General requirements placed on the fuel pump	Page 12
Connections for Bowden cable actuation and permissible load	Page 15
Technical data	Page 15
Requirements on cable actuation	Page 15

d05784.fm

# BRP-Powertrain

## INSTALLATION MANUAL

### Introduction

#### NOTICE

The design of the fuel system is the responsibility of the aircraft manufacturer.

The fuel system must be designed to ensure that the engine is supplied with sufficient fuel at the correct pressure in every operational situation. Operating limits must be adhered to!

#### NOTICE

Parallel hydraulic operation of the fuel pumps is not permitted. The fuel pressure regulator can not cope with the flow rate in this case and generator A can not deploy the high consumption of current (Error entry in the ECU).

#### NOTE:

It should be noted that the engine has an Eco and/or a Power-Mode. The Power-Mode is always active in Single-Lane operation and is decisive for the range calculation. The fuel consumption charts are available in the Operators Manual.

The fuel delivery is provided by two electric pumps connected in series with bypass valves and engine will operate with either one or both pumps running. The operating state of the pumps is manually selected. There are 2 injectors per cylinder (8 in. total). During engine run both injectors per cylinder are in operation. If a failure is detected in any one injector the injection period of the other one on that cylinder is adjusted for compensation.

The ECU operates all fuel injectors. A single blocked injector would be compensated automatically. If a problem with a fuel injector occurs, the fault is reported to the ECU and the pilot will be informed about a fault by the instrument panel.

---

# BRP-Powertrain

## INSTALLATION MANUAL

### Overview

### Fuel system

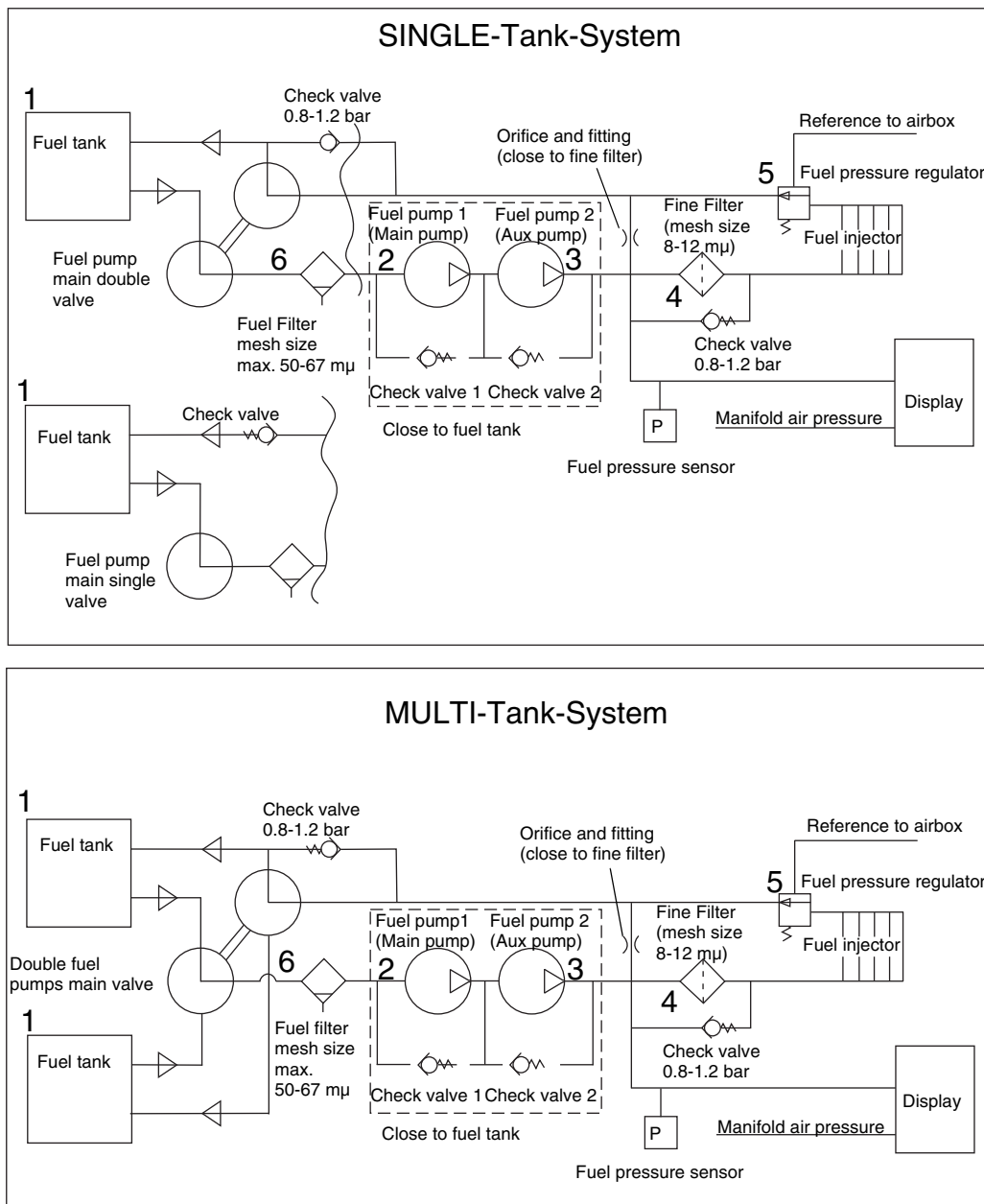

Part	Function
1	Fuel tank
2	Fuel pump 1
3	Fuel pump 2
4	Fine filter
5	Fuel pressure regulator
6	Coarse filter/water trap

Fig. 1

06293

d05784.fm

**BRP-Powertrain**  
INSTALLATION MANUAL

NOTES

d05784.fm

## 1) Requirements of the fuel system

### 1.1) Operating limits

#### General note

**NOTICE**

The design and layout of the entire fuel system must ensure engine operation within the specified operating limits.

**NOTICE**

In case of deviations in fuel pressure, the certification according to the latest requirements such as FAR or EASA must be carried out by the aircraft manufacturer.

See 912 i series Operators Manual, section 2.1) Operating Limits.

---

### 1.2) Fuel temperature

To avoid vapour locks, the fuel temperature must not exceed 45 °C (113 °F).

Vapour locks may form at fuel temperatures above 45 °C (113 °F).

The fuel system must be installed in such a way to avoid vapour lock.

Vapour lock may result in engine stoppage.

Should such problems occur during the test period, than the affected components, such as the supply line to the fuel pumps, must be cooled.

---

### 1.3) Fuel pressure indicator

#### General

The fuel pressure is adjusted by a mechanical pressure regulator. The pressure regulator is installed in the fuel line after Cyl. 4.

The reference pressure of the fuel system is the airbox pressure.

**NOTICE**

A fuel pressure indicator must be installed in the aircraft in such a way that it is clearly visible to the pilot.

---

#### 1.3.1) Location of the fuel pressure sensor

The fuel pressure sensor must be located before (upstream) the fine filter so that the load state of the fine filter can be monitored.

**Tip**

An increase of fuel pressure over the allowed limit means that the fine filter is becoming contaminated. The fine filter should be checked and replaced if necessary.

# BRP-Powertrain

## INSTALLATION MANUAL

### Tip

Due to different installation situations it is possible, that the fuel pressure deviates from the specified values in the Operators Manual (installation positions, filters, tank system, etc.).

The limits of fuel pressure at the fuel pressure regulator (see chapter 73-00-00 section: pressure measurement at "first installation") must be observed as described in the Operators Manual.

### 1.3.2) Pressure measurement at "first installation"

The fuel system must be checked at "first installation" <sup>1)</sup> of the 912 iS engine. A single measurement of the fuel pressure in a particular position is required by the engine manufacturer. This fuel pressure measurement deviates from the measurement position of the standard fuel pressure measurement (see IM Chapter 73-00-00;1.3.1). The fuel pressure sensor has to be positioned at the entrance to the fuel rail. For this measurement a calibrated measuring tool must be used. An appropriate verification must be available by the aircraft manufacturer.

NOTE: Remove this sensor after prototype/technical-release process.

<sup>1)</sup> "first installation" = for aircraft in prototype/technical-release process.

### 1.4) Fuel lines

#### Safety

#### WARNING

Non-compliance can result in serious injuries or death!

Certification according to the latest regulations, such as FAR or EASA, must be conducted by the aircraft or fuselage manufacturer.

#### NOTICE

To prevent problems with vapour formation, all the fuel lines must be insulated against heat in the engine compartment, routed at distance from hot engine components, without kinks and protected appropriately.

#### Inlet line

Connection thread on the right-hand injection line (Cyl. 1/3): M14x1.5 or AN-6 (9/16-18 UNF). The inlet line must have an inner diameter of minimum 7,5 mm (0.3 in.) (AN-6 or 3/8" ).

d05784.fm

# BRP-Powertrain

## INSTALLATION MANUAL

### Return line

#### NOTICE

With the engine switched off (throttle at idle and with both fuel pumps switched on), the pressure on the output of the fuel pressure regulator must not exceed 0.5 bar (10.15 psi) (relative to ambient pressure).

Connection thread on fuel pressure regulator: 9/16-18 UNF. The return line must have a minimum inner diameter of 7,5 mm (0.3 in.) (AN-6 or 3/8").

### Bypass line

To speed up the venting of the fuel system install a restricted bypass line between the inlet (pressure side of the fuel pump module) and the return line. In this bypass line a restricted jet must be installed so that there is control over the fuel flow rate.

The positioning and dimension of the jet is up to the aircraft manufacturer.

#### NOTICE

If no bypass line is installed, the pressure release in the fuel lines is very slow. This must be noted accordingly in the manuals of the aircraft manufacturer (fuel lines are possibly under full operating pressure even after engine stop).

The fuel lines must have a minimum inner diameter of 7,5 mm (0.3 in.) (AN-6 or 3/8").

#### Tip

For better heat dissipation select fuel lines made of metal whenever practicable (except for flex hoses to/from engine).

#### NOTE:

The switching between several fuel tanks at power loss due to fuel shortage must be given within a defined period of time and without falling below the minimum performance limit and must be ensured by the aircraft manufacturer. Refer to the latest requirements such as FAR or EASA.

### Screw clamp

Secure fuel lines with suitable screw clamps or by crimp connection.

### 1.5) Coarse filter

The coarse filter must be installed such that it is easily accessible for maintenance work and can be inspected as per the maintenance overview.

A coarse filter with mesh size from 50 - 67 micron (0.0019 in.-0.0026 in.) must be provided in the supply line between the tank and the fuel pumps. This filter must be of sufficient capacity to prevent complete blockage between maintenance intervals.

---

### 1.6) Water trap/Gascolator

A suitable water trap must be installed. Certification according to the latest regulations, such as FAR or EASA, must be conducted by the aircraft or fuselage manufacturer.

### 1.7) Fine filter

The fine filter must be installed so that it is easily accessible for maintenance work and can be inspected as per the maintenance overview.

The fine filter with following specifications must be installed between the fuel pumps (modul) and the injection rail (cylinder 1/3):

Filter mesh size: 8 - 12 micron (0.0003-0.0005 in.)

Fuel flow rate: min. 90 l/h

Differential pressure: max. 0.02 bar (0.29 psi)

---

### 1.8) GENUINE-ROTAX fuel pump assy.

**NOTICE**

Fuel pumps are permitted in connection with the GENUINE-ROTAX steel housing only. When not using this assy., the aircraft manufacturer has to perform all tests according to the latest construction regulations.

**NOTE:** The GENUINE ROTAX fuel pump unit has been tested and approved according to CS-3-130. Thus, the fuel pump unit can be installed to the firewall without additional fire protection.

The electrical fuel pump must be attached near the tank, taking advantage of a "cool" installation position in order to ensure a safe fuel supply, especially with regard to the risk of vapour lock. The pump must be free of vibrations and installed low, if possible below the level of the fuel tank outlet.

d05784.fm



## BRP-Powertrain

### INSTALLATION MANUAL

**NOTE:** The cable length for the fuel pumps can be extended, if necessary. For this a ROTAX plug kit is available.

**NOTICE**

Do not connect additional load (additional fuel pumps, lamps, LED, etc.) to the power supply of the fuel pumps.

The wiring is manufactured for the GENUINE ROTAX fuel pump assy. only.

#### 1.8.1) Current input (Operating condition of the fuel pumps: ON)

Voltage	Current
12 V	9.1 A
14 V	10.1 A
16 V	11.2 A

**BRP-Powertrain**  
INSTALLATION MANUAL

**1.8.2) Technical data**

Graphic

The technical data of the fuel pumps provided by ROTAX is shown below. See [Fig. 2](#) and [Fig. 3](#).

a) Dimensions: Connection 9/16-18 UNF

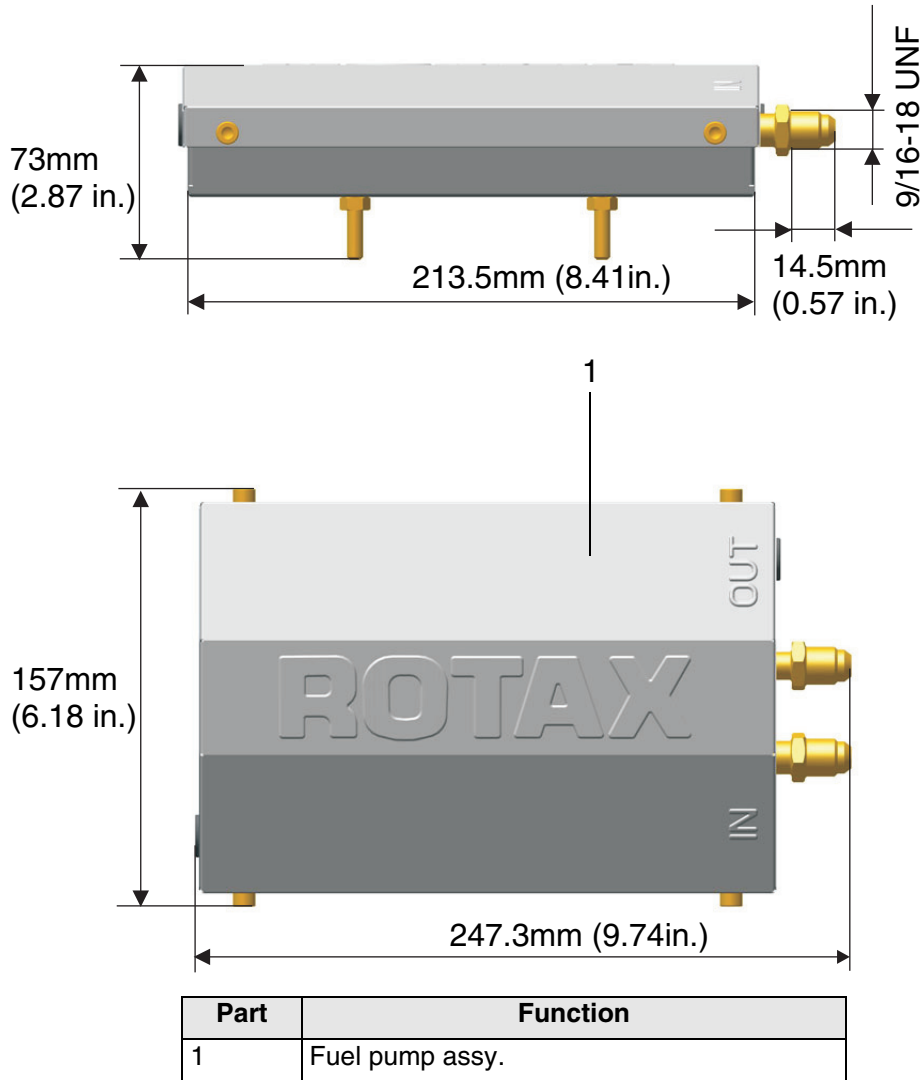

Fig. 2

06333

d05784.fm

**BRP-Powertrain**  
INSTALLATION MANUAL

b) Dimensions: Connection M14x1.5 metric

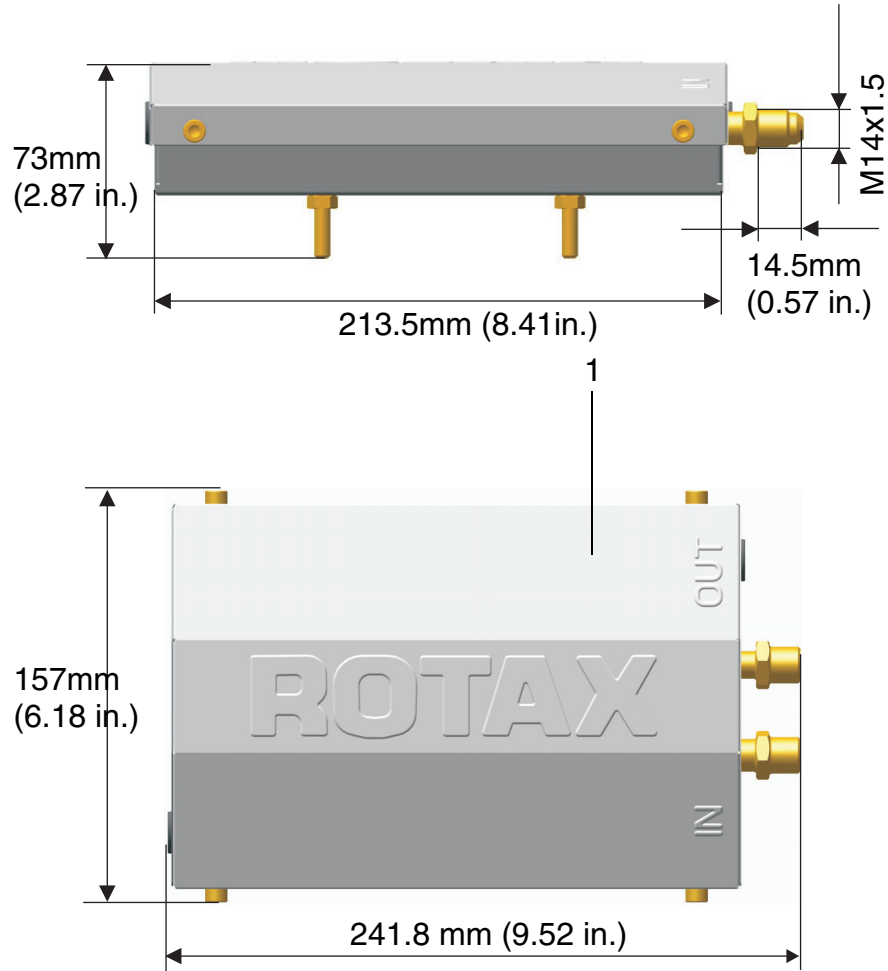

Part	Function
1	Fuel pump assy.

Fig. 3

06398

Housing:	stainless steel
Nominal voltage:	12 V
Capacity:	approx. 120 l/h (31.7 US gal/h)
Pressure:	min. 4.5 bar (65.3 psi) (absolute pressure)
Absorption capacity:	up to -400 mbar (-5.8 psi) compared to ambient (depending on the vapor pressure of the fuel used)
Check valves:	a) opening pressure max. 70 mbar (1.02 psi) b) resistance max. 70 mbar at 75 l/h (19.8 US gal/h) c) pressure safe up to 20 bar (290 psi)

d05784.fm

### 1.8.3) General requirements placed on the fuel pumps

**⚠ WARNING**

Non-compliance can result in serious injuries or death!  
The pressure in the return line must not exceed the value stipulated in section 1.4.

Requirement	regarding delivery
Min. delivery rate	56 l/h (14.79 US gal/h)
Min. fuel pump pressure	4.5 bar (65.26 psi) absolutely (at sea level)

**Power supply wires**

**NOTE:** If the length of the power supply line is insufficient, it can be extended. A ROTAX connector set is available.

**NOTICE**

The responsibility for correct implementation and use of the power supply wires between harness connector and fuel pump is up to the aircraft manufacturer or the authorized Service Center, which performs the work.

For use as a power supply line for supplying the fuel pumps off the standard wiring harness, a line insulated with PTFE, ETFE or higher has to be used. The construction regulations for each aircraft class are mandatory and have to be applied and complied with.

**Wire size**

The cross-section of the power supply wire must be at least 1.5 mm<sup>2</sup>/ 16 AWG (0.0023 in<sup>2</sup>) of stranded, coated copper. The length of the power supply wire between the harness connector and fuel pump must be selected so that the voltage drop along the additional wire does not exceed < 500 mV.

In accordance with the construction regulations, the aircraft manufacturer or the approved Service Center can also develop their own cable design.

**NOTICE**

The aircraft manufacturer or the approved Service Center must ensure that the fuel pump is supplied with sufficient electrical energy to maintain the required minimum values for the engine and the fuel pressure and volume flow in each operating state and in every flight attitude.

d05784.fm

# BRP-Powertrain

## INSTALLATION MANUAL

**Wire construction** The wire construction must be a shielded twisted pair cable (STP, 40x twisted per meter) to meet the requirements of the EMC Directive (electromagnetic compatibility).

### Tip

#### Tip

In case of supply problems of the fuel pump, the fuel tank should be emptied and filled with AVGAS. If the problem does not occur at the next test (with AVGAS), then this is a sign of formation of vapor bubbles when using MOGAS (or auto fuel).

#### Tip

Tips that will have a favorable impact on the installation of the 912 iS/iSc:

- Single tank (large volume of fuel in the tank, just a few fuel lines)
- Catchtanks in the wing tanks. This provides the fuel supply in every flight situation/position

Headertank (the following reference values should be considered):

- Tank should be made of light metal
- Tank volume at least 5 l (1.32 US gal)
- A sump should be integrated into the headertank
- Provide connection for a "Low Fuel" sensor
- The venting line from header tank to wing tank should generally be on an incline to avoid trapping bubbles. The venting line must have an inner diameter of at least 12 mm (0.50 in)
- Fuel feed lines from the wing tanks to the header tank should be on a steady decline

#### Tip

Information about properties which have proved unfavorable impact on the installation of the 912 iS/iSc:

- Fuel lines smaller than 7.5 mm (0.30 in) (AN-6 or 3/8") of inner diameter
- Multi-tank systems without Catch-, Headertank
- Coarse or fine filter not in use
- Fuel cock position on the pressure side of the fuel system (after the fuel pump module)

d05784.fm

## BRP-Powertrain

### INSTALLATION MANUAL

**Tip**

Fuel pressure regulators have very precise tolerances and are generally reliable. Pressure fluctuations are not caused by the pressure regulator, they have to be searched in other areas (filter clogged, pulsation of lines, kinks in the hoses, etc.) of the fuel system, before troubleshooting the pressure regulator.

**Tip**

Vapor bubbles in the return line must be efficiently vented out of the fuel system to atmosphere. Adequate fuel tank venting system design is imperative. Large vent lines with (most) direct routing avoiding low points are desired.

**Tip**

A header tank design that efficiently jets vapour bubbles back to the fuel tanks and atmosphere without possibility of re-entry into the suction line, is critical.

**Tip**

Non drainable low points in feed, return and vent lines must be avoided.  
Any low points must allow for drainage of water and other contaminants.

 **WARNING**

At the low points, accumulations of water can freeze and cut off the flow.

d05784.fm

# BRP-Powertrain

## INSTALLATION MANUAL

### 2) Connections for throttle bowden cable actuation and permissible load

General note

**NOTICE**

The specified permissible loads must never be exceeded!

#### 2.1) Technical data

Connections

Connection for throttle valve:

Connection on throttle lever:	Set screw M6x12
Tightening torque:	4 Nm (3.32 lb ft) (suitable for flexible cable), 1.5 mm (0.06 in.) steel rope or single-strand wire)
Cable travel:	65 mm (2.56 in.)
Actuating force:	Min. 7.5 N (1.69 lb-force) Max. 20 N (4.5 lb-force)
Max. permissible actuating force:	20 N (4.5 lb-force)

#### 2.2) Requirements on cable actuation

Throttle lever not connected

**⚠ WARNING**

Non-compliance can result in serious injuries or death! With throttle lever not connected the throttle valve will remain fully open. **The starting position of the throttle valve is therefore full throttle!** Therefore never start the engine without connecting the throttle lever.

**⚠ WARNING**

Non-compliance can result in serious injuries or death!  
The cable actuations being used must not be affected at all by vibrations emanating from the engine or the airframe.

Bowden cable

The Bowden cable must be adjusted so there is free travel of 1 mm (0.039 in).

Throttle lever stop

The idle speed must not be adjusted by a throttle stop in the cockpit. The throttle lever must contact the idle speed stop screw on the engine (idle speed, see latest Operators Manual).

d05784.fm

# BRP-Powertrain

## INSTALLATION MANUAL

Graphic

Cable actuation

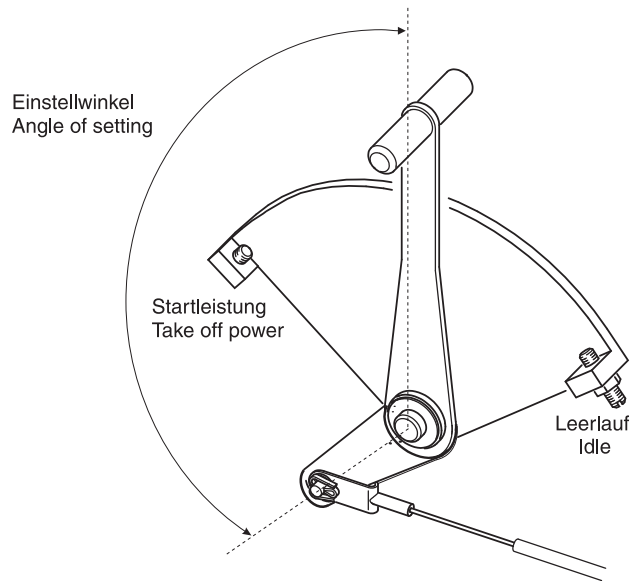

05912

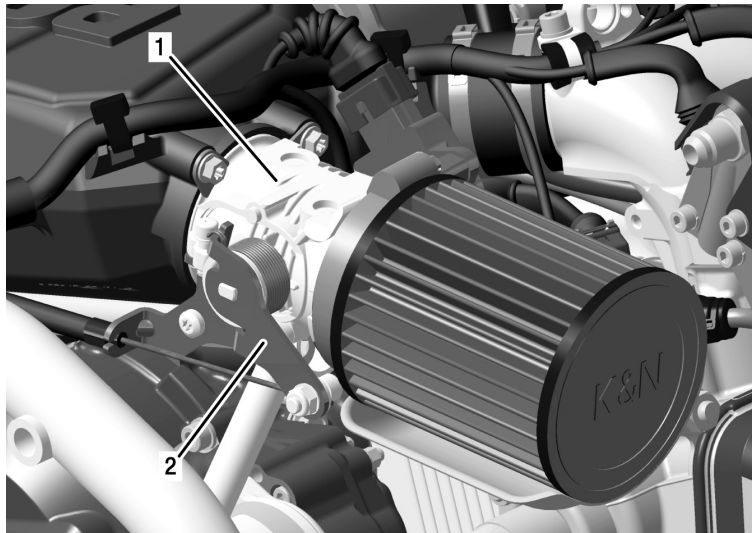

06477

Part	Function
1	Throttle valve
2	Throttle lever

Fig. 4

**⚠ WARNING**

Non-compliance can result in serious injuries or death! Adjust Bowden cable such that throttle valve can be fully opened and closed. Use Bowden cable with minimized friction so that the return spring on the throttle valve can open the throttle valve completely.

d05784.fm



**BRP-Powertrain**  
INSTALLATION MANUAL

**Chapter: 74-00-00**  
**IGNITION SYSTEM**

**Introduction**

The ignition system is powered by the ECU and has fully mapped variable timing. It is completely doubled up. Either of the ECU's can operate the double ignition coils. If a fault occurs with the ignition system the ECU informs the pilot by warning lamps through the display in the instrument panel.

**NOTE:** All components are installed on the aircraft engine as standard.

**Table of contents**

This section of the Installation Manual contains information on the aircraft engine ignition system.

Subject	Page
Connection to rectifier regulator	<a href="#">Page 3</a>

# BRP-Powertrain

## INSTALLATION MANUAL

### Overview

### Ignition system

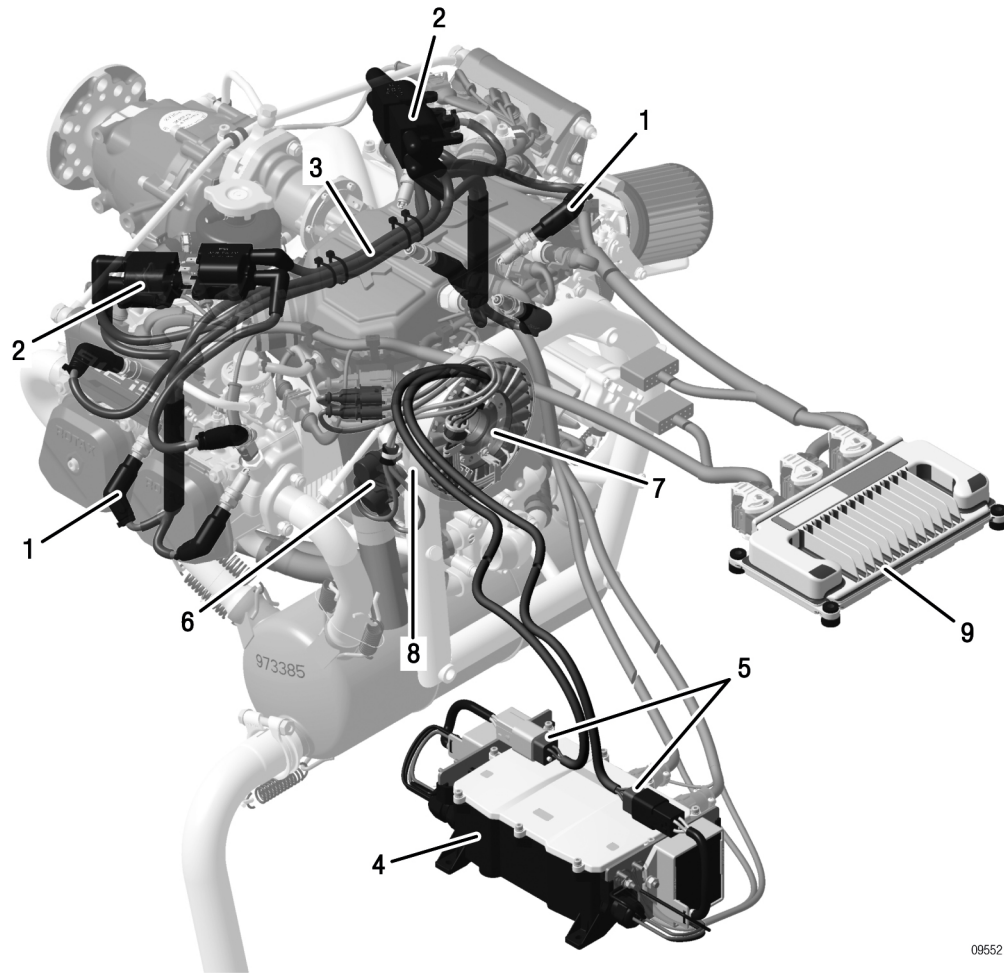

09552

Part	Function
1	Resistance spark plug connector
2	Dual ignition coil
3	Ignition cable
4	FUSE BOX assy.
5	Electrical LINE A+B with connectors
6	Crankshaft position sensors
7	Stator assy.
8	Fly wheel
9	ECU

Fig. 1

File: d05395.fm

**BRP-Powertrain**  
INSTALLATION MANUAL

## 1) Connection to rectifier regulator

**General note**



Non-compliance can result in serious injuries or death!

The general safety information must be observed for all work on the aircraft engine and its surrounding components.

The following components must be connected for proper operation of the ignition system.

**NOTICE**

Connecting the components incorrectly will mean that there will not be enough energy for the on-board power supply or to charge the battery!

**NOTICE**

The two connectors are coloured differently to prevent them being connected incorrectly:

- Black for generator A LINE - rectifier regulator (A)
- Grey for generator B LINE - rectifier regulator (B)

**NOTE:**

Generator A is only used for electronic engine components (ignition, injection and sensors).

Generator B is used primarily to start the engine (Generator B is in use till 2400 rpm longer than 3 sec, then the ECU automatically switch over to generator A) and to charge the aircraft battery.

**BRP-Powertrain**  
INSTALLATION MANUAL

Graphic

Ignition system

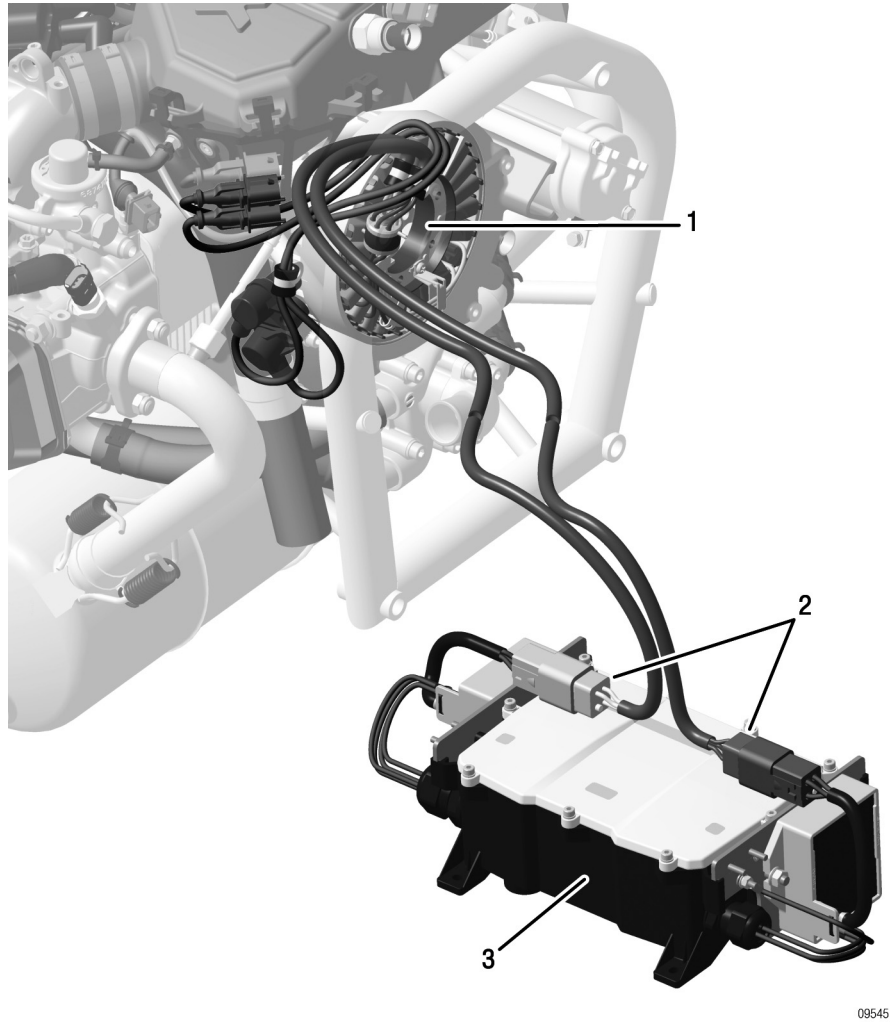

Part	Function
1	Internal generator
2	Electrical LINE A+B with connectors
3	FUSE BOX assy.

*Fig. 2*

06326

**BRP-Powertrain**  
INSTALLATION MANUAL

**Chapter: 75-00-00**  
**COOLING SYSTEM**

**General note**

The shape, size and position of the radiator(s) depends mainly on the space available in the aircraft.

When correctly installed in the aircraft, the optionally available BRP-Powertrain radiator has enough cooling capacity to keep within the standard specified operating limits. The flow resistance of the radiator coolant is correctly adjusted to the cooling system. The tube size must be sufficient. The size, shape, orientation of all cooling components must not compromise the engine cooling under all operation conditions.

**Table of contents**

This chapter of the Installation Manual contains system description, operating limits and requirements for the aircraft engine cooling system.

Subject	Procedure
Cooling system	<a href="#">Page 3</a>
System description	<a href="#">Page 3</a>
Operating limits	<a href="#">Page 5</a>
Coolant types	<a href="#">Page 6</a>
Checking the efficiency of the cooling system	<a href="#">Page 7</a>
Cooling system requirements	<a href="#">Page 8</a>
Connecting sizes and position of connections	<a href="#">Page 11</a>
Requirements, permissible position and installation position of radiator, expansion tank, overflow bottle	<a href="#">Page 12</a>
ROTAX overflow bottle	<a href="#">Page 15</a>
General notes on the cooling system	<a href="#">Page 17</a>
Coolant capacity	<a href="#">Page 18</a>
Cooling air duct	<a href="#">Page 19</a>
General notes on the cooling air ducts	<a href="#">Page 20</a>
Data for optional components of cooling system	<a href="#">Page 21</a>

# BRP-Powertrain

## INSTALLATION MANUAL

### Overview

### Cooling system

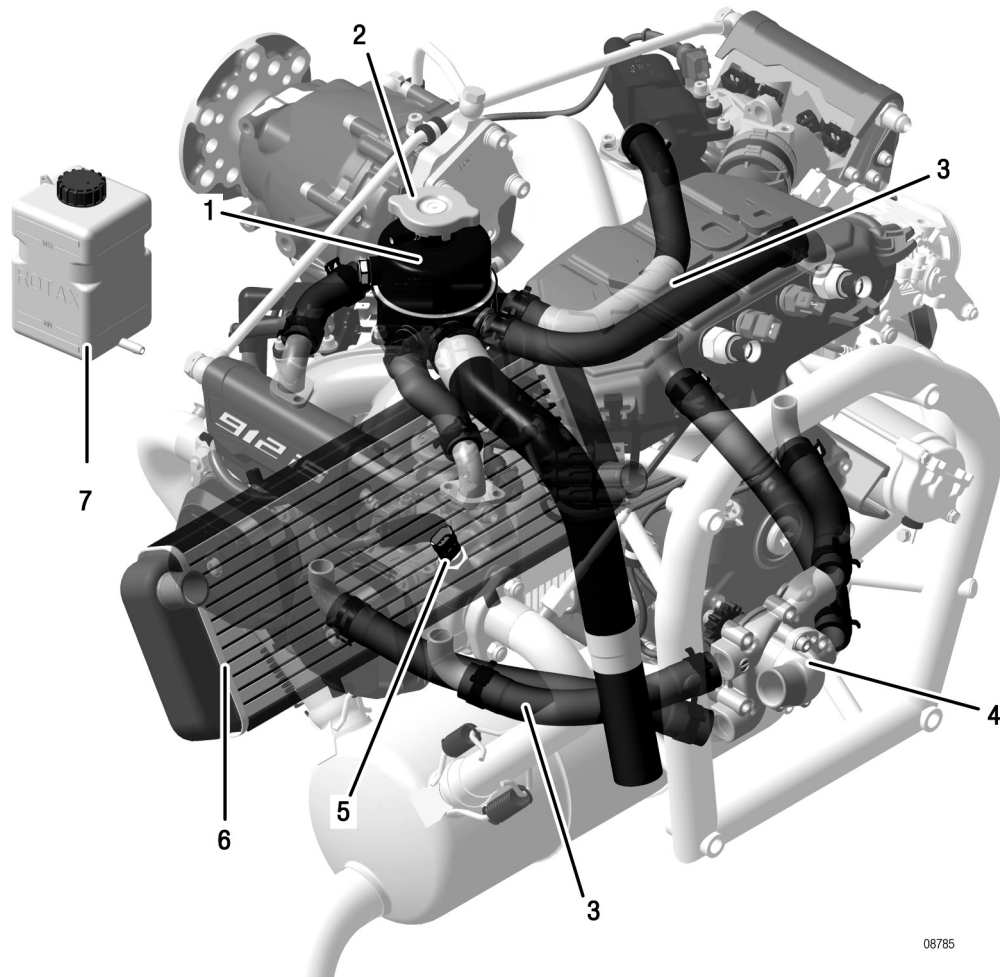

Part	Function
1	Expansion tank
2	Radiator cap
3	Coolant hose
4	Water pump housing
5	Temperature sensor
6	Radiator
7	Overflow bottle

Fig. 1

**BRP-Powertrain**  
INSTALLATION MANUAL

## 1) Cooling system

### 1.1) System description

<b>Cooling</b>	See <a href="#">Fig. 2</a> .  The engine cooling system is designed for liquid cooling of the cylinder heads and ram air cooling of the cylinders.  The cooling system of the cylinder heads is a <b>closed</b> circuit with an expansion tank and overflow bottle.
<b>Coolant</b>	The coolant flow is forced by a water pump, driven from the camshaft, from the radiator to the individual cylinder heads. The coolant flows from the top of the cylinder heads to the expansion tank (1). Since the standard location of the radiator (3) is below engine level, the expansion tank located on top of the engine allows for coolant expansion.
<b>Expansion tank</b>	The expansion tank is closed with a pressure cap (2) (with pressure relief valve and return valve). As the coolant heats up and expands, the pressure relief valve opens and the coolant flows via a thin hose at atmospheric pressure to the transparent overflow bottle (4). As it cools down, the coolant is sucked back into the cooling circuit.
<b>Shape, size and position</b>	The shape, size and position of the radiator(s) depends mainly on the space available in the aircraft.
<b>Measuring the coolant temp.</b>	NOTE:           The coolant temperature sensor is in cylinder head 4.
<b>Radiator</b>	If a GENUINE-ROTAX radiator is being used, then an oil-water heat exchanger must not be present. The radiator is dimensioned to cater for the heat of the coolant and cannot cope with the additional heat generated by the oil system.

# BRP-Powertrain

## INSTALLATION MANUAL

Graphic

Cooling system

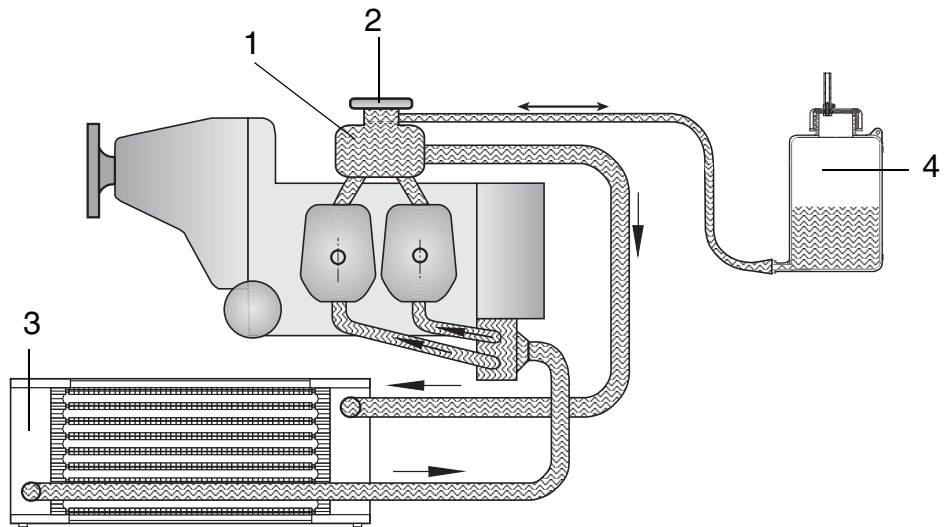

Part	Function
1	Expansion tank
2	Pressure cap
3	Radiator
4	Overflow bottle

Fig. 2

09152



# BRP-Powertrain

## INSTALLATION MANUAL

### 1.2) Operating limits

#### General note



Non-compliance can result in serious injuries or death!  
The cooling system must be designed so that operating temperatures will not exceed the maximum values.

#### Optional radiator

When correctly installed in the aircraft, the optionally available BRP-Powertrain radiator has enough cooling capacity to keep within the standard specified operating limits. The flow resistance of the radiator coolant is correctly adjusted to the cooling system. The tube size must be sufficient.

#### Boiling point of the coolant

Monitoring the cooling system is important for controlling engine cooling and prevent knocking combustion within the operating limits. It is important that the coolant circuit is designed so that the coolant does not reach boiling point under any conditions. If the temperature exceeds the boiling point, the engine can quickly overheat due to loss of coolant.

The boiling point of the coolant is mainly influenced by:

- the type of coolant
- mixture ratio (percentage water rate)
- the system pressure (opening pressure of radiator cap)

#### Coolant temperature

Coolant temperature: (coolant exit temperature)	
Max.	120 °C (248 °F)

**BRP-Powertrain**  
INSTALLATION MANUAL

### 1.3) Coolant types

**General note**

**NOTICE**

Using waterless coolant is not permitted (e.g. Evans).

Permissible coolant types:

Description	
1	Conventional coolant based on ethylene glycol

**NOTICE**

When selecting a suitable coolant, the information in Service Instruction SI-912 i-001, latest issue, must be observed.

**Conventional coolant**

Conventional coolant is recommended as it commonly available and has a greater thermal heat transfer capability. Its limitation is its lower boiling point.

**Mixing ratio**

**NOTICE**

The manufacturers instructions regarding the coolant must be observed.

Description	Mixture ratio	
	Concentration	Water
Conventional coolant	50 %	50 %
Some conventional coolants are available pre-mixed by the manufacturer. In this case do not mix with water, instead follow the manufacturers instructions.		

**Boiling point**

**Conventional coolant:**

Conventional coolant mixed with 50 % water cannot boil at a temperature below 120 °C (248 °F) at a pressure of 1.2 bar (18 psi). The max. coolant temperature limit is therefore 120°C (248 °F).

**Marking**

Marking of the coolant to be used

**NOTICE**

The coolant to be used and its concentration (percentage water rate) must be correctly communicated to the owner.

## 2) Checking the efficiency of the cooling system

**General note**      The maximum coolant temperature must be determined in order to check the efficiency of the cooling system.

---

**Measurement of coolant temperature**      See Fig. 3.  
The coolant temperature is measured using temperature sensor (1), which is installed on cylinder 4.

---

**Graphic**      Coolant temperature sensor

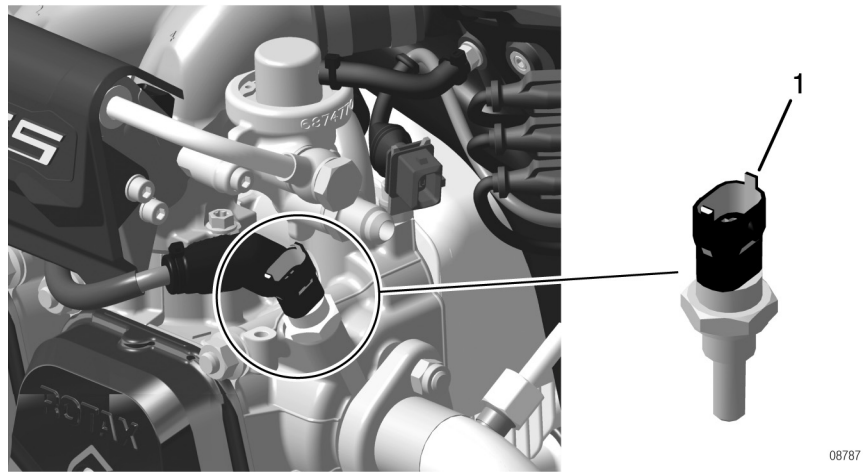

*Fig. 3*

---

**Coolant exit temperature**      See Fig. 4.

**WARNING**

Non-compliance can result in serious injuries or death!  
Do not restrict the coolant flow with the sensor.

**NOTICE**

It is possible to record a false measurement when measuring fluid temperatures. If fluid volume is lost and the sensor is not fully submerged in the liquid, the indicating instrument could incorrectly display a lower temperature, by measuring the air temperature instead of the coolant temperature.

---

## 2.1) Cooling system requirements

### Safety

**⚠ WARNING**

Non-compliance can result in serious injuries or death!  
The cooling system must be designed so that the operating limits are not exceeded.

To minimize flow resistance, use radiators that have both a parallel flow and have a low flow resistance. A prime example would be the GENUINE-ROTAX radiators. Be sure to use short hoses and pipelines.

**NOTICE**

All components of the cooling system must be suitably secured.

### Coolant hoses

See Fig. 4.

**NOTICE**

Hoses exposed to direct heat radiation from the exhaust system, must be suitably protected with heat-resistant protection tubes, for example.

NOTE: Aluminium tubes with an inner diameter of 25 mm (0.98 in.) can be used instead of longer hoses. These must have a bulge (1) in order to prevent coolant hoses working loose. Note as well that this will double the number of hose clips required!

- Temperature resistance, min. 125 °C (257 °F)
- Pressure durability: min. 5 bar (72 psi)
- Inner diameter: 25 mm
- Bending radius: min. 175 mm (6.89 in.) (except moulded hoses)
- Material: 100 % resistant to glycol, antifreeze and ozone.

### Graphic

Drawing aluminium tube

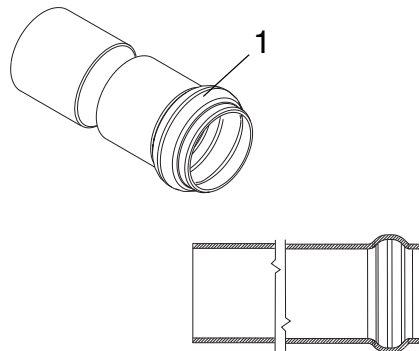

Fig. 4

09158

d05785.fm

# BRP-Powertrain

## INSTALLATION MANUAL

Hose connect-  
ing expansion  
tank

### Hose from expansion tank to overflow bottle:

See Fig. 5.

**⚠ WARNING**

Non-compliance can result in serious injuries or death!  
A soft walled hose is not suitable as it can collapse and cause cooling system failure.

- The hose from the expansion tank to the overflow bottle must be rated for vacuum/suction for min. 125 °C (257 °F), e.g. it must be strong enough to withstand high temperatures and vacuum/suction during the cooling down period.

The aircraft manufacturer must give the possibility to the pilots to check the coolant level in the expansion tank. Also it is necessary to inform the pilots about the daily inspection of the coolant level in the aircraft manufacturers operators (pilots) manual or an adequate link to the ROTAX 912 i Series Operators Manual.

It is recommended that adequate measures are taken for carrying out these inspections, e.g. a flap or panel on the cowling or a warning instrument in the cockpit for low coolant level.

Graphic

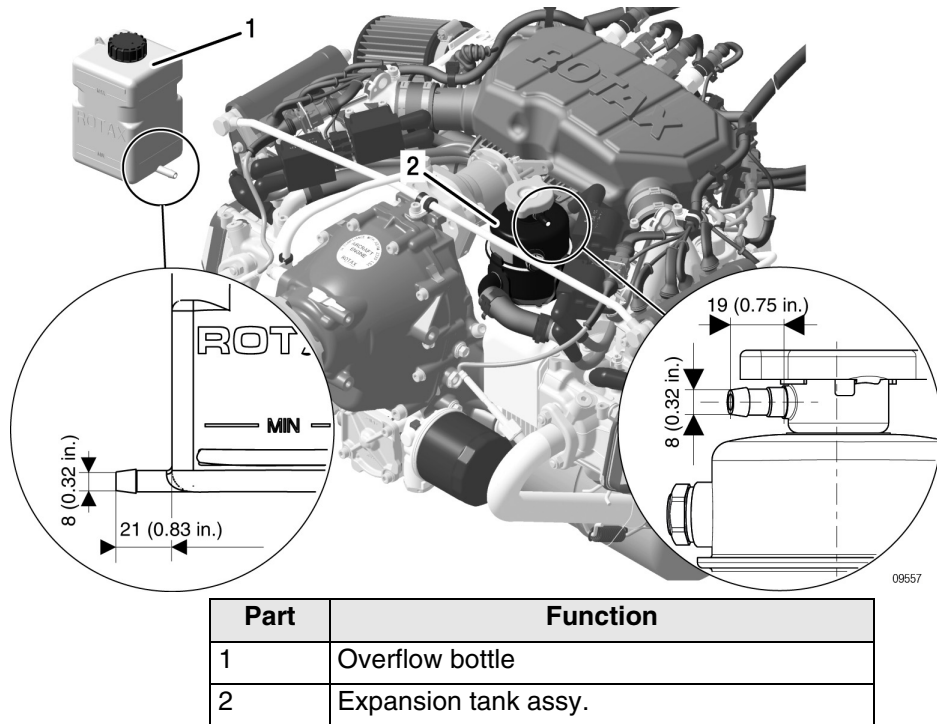

Fig. 5

d05785.fm

**BRP-Powertrain**  
INSTALLATION MANUAL

NOTES

**BRP-Powertrain**  
INSTALLATION MANUAL

**3) Connecting sizes and position of connections**

General note See Fig. 6.

**NOTICE** The hoses must be fixed with appropriate clips to prevent loss, e.g. with spring type hose clips, such as those used for the coolant hoses between the water pump and cylinder. Clips of this type have performed well in the field.

Graphic

Connecting sizes

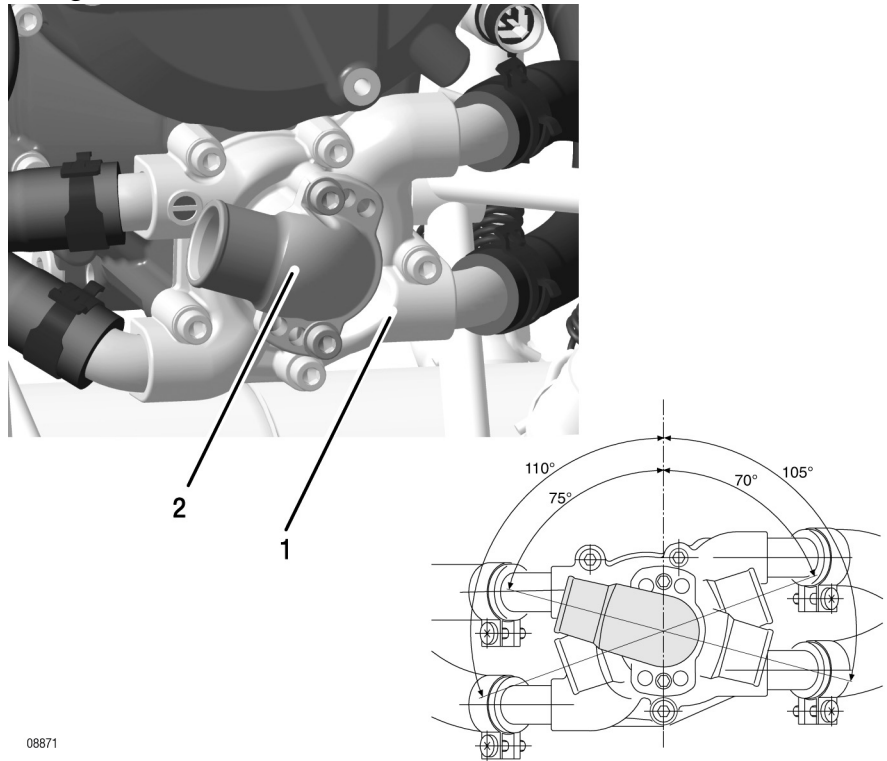

Part	Function
1	Water pump housing
2	Water inlet elbow

Water inlet elbow: Outer diameter 27 mm (1.06 in.)

Slip-on length: max. 19 mm (0.75 in.)

*Fig. 6*

d05785.fm

# BRP-Powertrain

## INSTALLATION MANUAL

Water inlet elbow

**NOTICE**

Use the total slip-on length for the water inlet elbow and expansion tank. Secure hoses with suitable spring or screw clamps.

NOTE:

Choose between six possible installation positions of water inlet elbow (2) appropriate to specific installation (see illustration).

Use two M6x20 Allen screws and lock washers to attach the water inlet elbow. Tighten screws to 10 Nm (90 in.lb.).

---

### 3.1) Requirements, permissible location and installation position of the radiator/expansion tank/overflow bottle

Radiator

See Fig. 7.

**⚠ WARNING**

Non-compliance can result in serious injuries or death! The radiator must be designed and installed such that the permissible operating temperatures are maintained and the max. values are not exceeded. This must also apply to "**Hot day condition**".

**NOTICE**

If required, the radiator outlet (3) may be located max. 1.5 m (4.92 ft.) underneath the inlet elbow (4) of the water pump and no higher than the expansion tank (1).

---

Expansion tank

To ensure proper operation of the cooling system, the expansion tank (1) with pressure cap (2) in the main operating systems must be installed on the highest point of the cooling circuit.

NOTE: The expansion tank (1) is fitted on top of the engine.

---



**BRP-Powertrain**  
INSTALLATION MANUAL

Graphic

Permitted installation positions

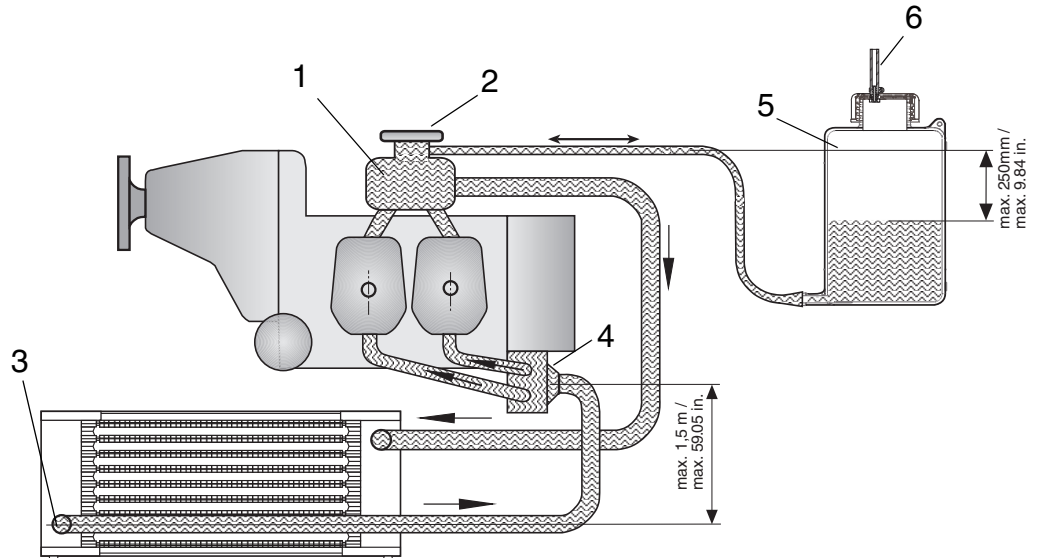

Part	Function
1	Expansion tank
2	Pressure cap
3	Radiator outlet
4	Water inlet elbow
5	Overflow bottle
6	Purging

Fig. 7

08319

**Overflow bottle**

The system also needs an overflow bottle in which surplus coolant is collected and returned to the coolant circuit during the cooling down period.

**NOTICE**

To ensure proper operation of the cooling system, the suction height between overflow bottle and expansion tank must not exceed 250 mm (10 in.).

**NOTE:**

For proper operation ensure that the hose to the overflow bottle is as short as possible.

d05785.fm

**BRP-Powertrain**  
INSTALLATION MANUAL

**Overflow bottle requirements**

- Transparent material
- Temperature resistant from -40 °C to +130 °C (-40 °F to 266 °F)
- 100 % resistant to glycol and suitable for all other antifreeze agents
- Volume approx. 0.5 l. (0.13 USgal)
- With vent (6), diameter 2.5 mm (0.1 in.)

NOTE: The overflow bottle should be furnished with a label indicating function and content.

---

**Capacity**



Non-compliance can result in serious injuries or death! The overflow bottle must never be empty, otherwise air will be sucked into the cooling circuit; this can have a negative effect on the safe operation of the engine.

---

**Installation**



The overflow bottle and its supply and discharge must not be installed close to the exhaust system, as emerging coolant can be flammable under certain conditions.

---

# BRP-Powertrain

## INSTALLATION MANUAL

### 3.2) ROTAX overflow bottle (optional extra)

**General note** If the optional ROTAX overflow bottle is used, the purging system must be arranged as shown below.

**Retrofitting** **NOTE:** To vent coolant steam from the overflow bottle in case of overheating, the plastic cap can be retrofitted with a hose nipple and hose (see Fig. 8).

The purging line (5) must be routed so that coolant cannot come in contact with the hot exhaust system.

The vent line must be routed in a continuous decline or furnished with a drain bore at its lowest point to drain any condensation.

The line must be protected from any kind of ice formation from condensation, e.g. insulation protection or routing in a hose with hot air flow and furnishing the line with a bypass opening before the cowling outlet.

**Work instruction** See Fig. 8.

Procedure for attaching the hose nipple:

Step	Procedure
1	Unscrew the plug screw (2) from the overflow bottle.
2	Bore the existing purging hole from dia. 2.5 mm (0.10 in.) to dia. 6 mm (0.236 in.).
3	Apply LOCTITE 603 to the threads of the hose nipple (3).
4	Insert hose nipple (3) with the thread first into the vent hole.
5	Fix M6 hex. nut (1) onto the hose nipple (3). Tightening torque 5 Nm (3.69 lbft).
6	Screw the plug screw onto the overflow bottle.

Steps for attaching the hose.

Step	Procedure
1	Secure the hose with a gear-type hose clip (4) or spring type hose clip.
2	Secure and route the hose (5) without kinks.

**BRP-Powertrain**  
INSTALLATION MANUAL

Graphic

Hose nipple

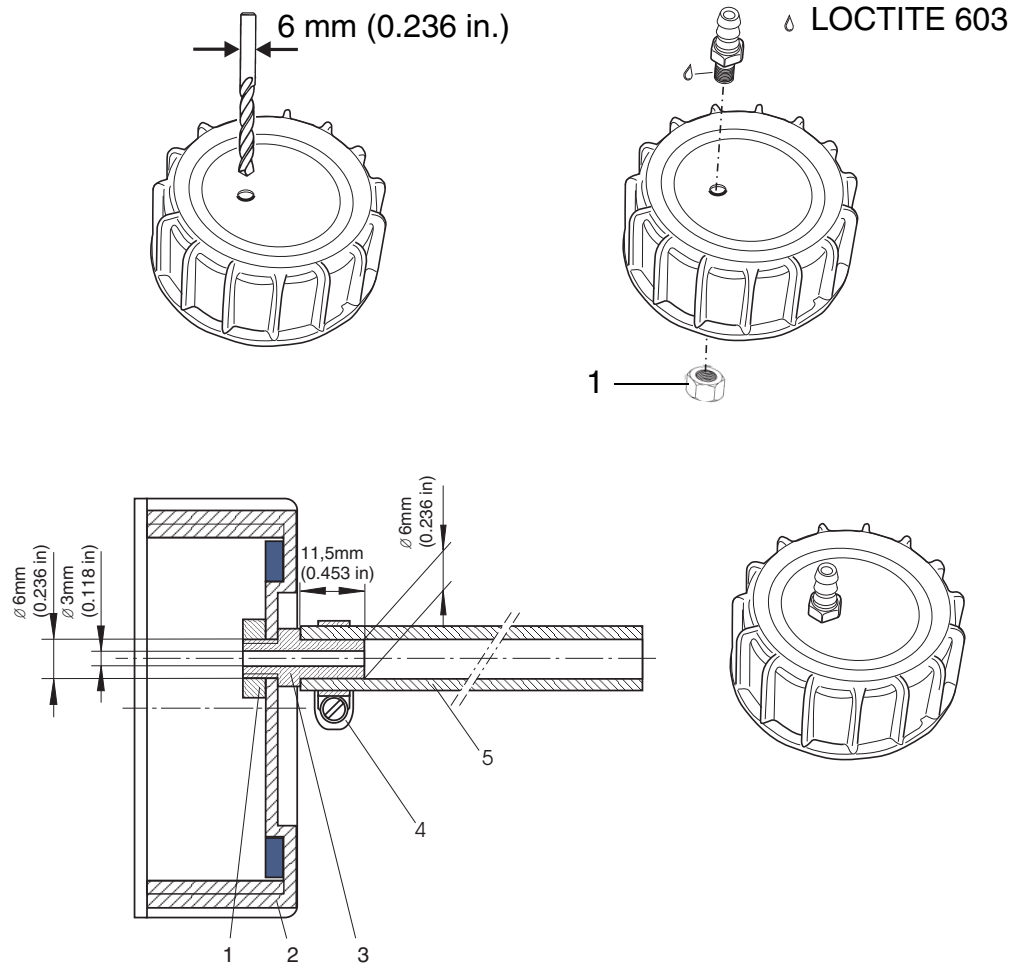

Part	Function
1	M6 hex. nut
2	Plug screw
3	Hose nipple
4	Gear-type hose clip
5	Hose

Fig. 8

05033.09126

# BRP-Powertrain

## INSTALLATION MANUAL

### 4) General notes on the cooling system

#### Certification



**WARNING**

Non-compliance can result in serious injuries or death! Certification according to the latest regulations, such as FAR or EASA, must be conducted by the aircraft or fuselage manufacturer.

Essential parts of the cooling system, such as radiator, etc., are available for this engine from BRP-Powertrain.



**WARNING**

Ensure that no contact with hoses or hose clamps of the engine is given (risk of chafing, wear, loss of coolant) at the installation of external components (governor, vacuum pump).

#### Radiator

**NOTICE**

The radiator must be designed to dissipate approx. 30 kW (7.58 BTU/s) of thermal energy at take-off performance.

In an installation as depicted with the radiator (1) in a higher position than the standard supplied expansion tank (3), a water accumulator (2) has to be fitted instead of the expansion tank (3). Additionally a suitable expansion tank (3) has to be installed at the highest point of the cooling circuit.

**NOTE:** Experience has shown that with good airflow, a radiator with an area of 500 cm<sup>2</sup> (77.5 in<sup>2</sup>) is required for trouble-free operation.

#### Graphic

Radiator

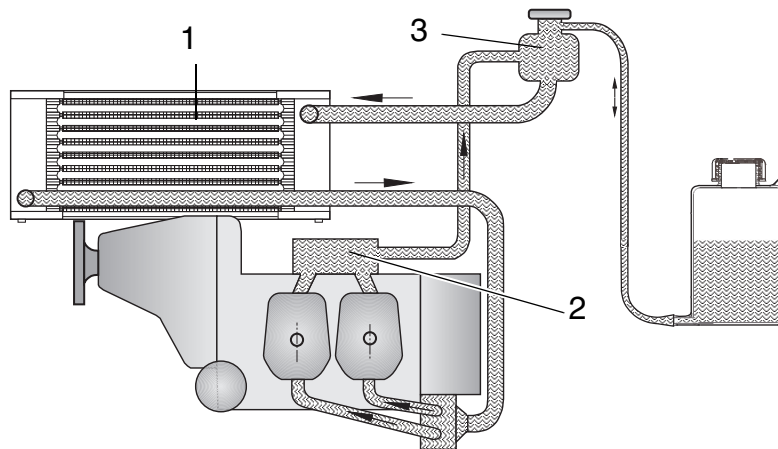

Part	Function
1	Radiator
2	Water accumulator
3	Expansion tank

Fig. 9

08320

d05785.fpp

**BRP-Powertrain**  
INSTALLATION MANUAL

**Flow rate** The flow rate in the coolant circuit is approx. 60 l/min (15.85 USgal/min.) at 5800 rpm. At full throttle, an approximate value of around 0.75 m<sup>3</sup>/s (28.59 cu.ft/sec) can be assumed for the required cooling air flow.

---

**Flow resistance** The flow resistance of the coolant in the optional ROTAX radiator is correctly adjusted for the cooling system.  
If using other radiators, check the flow rate and cooling capacity.

---

**Installation of the radiator** No provision has been made for attachment of the radiator(s) on the engine (rubber mounts are recommended).

**NOTICE**

The radiator must be installed without distortion or stress and be free of vibrations. If a GENUINE ROTAX radiator is not being installed, ensure sufficient cooling capacity.

---

**4.1) Coolant capacity**

4 cylinder heads.....	560 cm <sup>3</sup> (0.02 cu.ft)
Coolant pump.....	100 cm <sup>3</sup> (0.004 cu.ft)
Expansion tank .....	250 cm <sup>3</sup> (0.008 cu.ft)
2 m coolant hose (inner ø 18 mm) .....	500 cm <sup>3</sup> (0.018 cu.ft)
Total coolant quantity for engine.....	approx. 1.5 l (0.4 USgal)

---

## 4.2) Cooling air ducts (optional)

**General note** Cooling air ducts are not required if the oil and coolant temperatures are within the prescribed operating limits. Otherwise following measurement must be performed for the first installation of an aircraft type (not in serial production).

**Hot day condition** See Fig. 10.

In contrast to the cylinder heads, the cylinders are ram air cooled. Plan the cooling air ducts according to installation requirement.

**⚠ WARNING**

Non-compliance can result in serious injuries or death! The cooling air ducts must be designed and built such that the operating temperatures are within the specified limits and maximum values are not exceeded. This must also apply to "**Hot day condition**".

Max. permitted cylinder wall temperature on hottest cylinder...200 °C (392 °F)

**NOTE:** If this temperature is exceeded, appropriate measures (e.g. cooling air ducts, modifications to cowling, etc.) must be taken to bring it within limits again.

**| Graphic**

Measuring point for Hot day condition

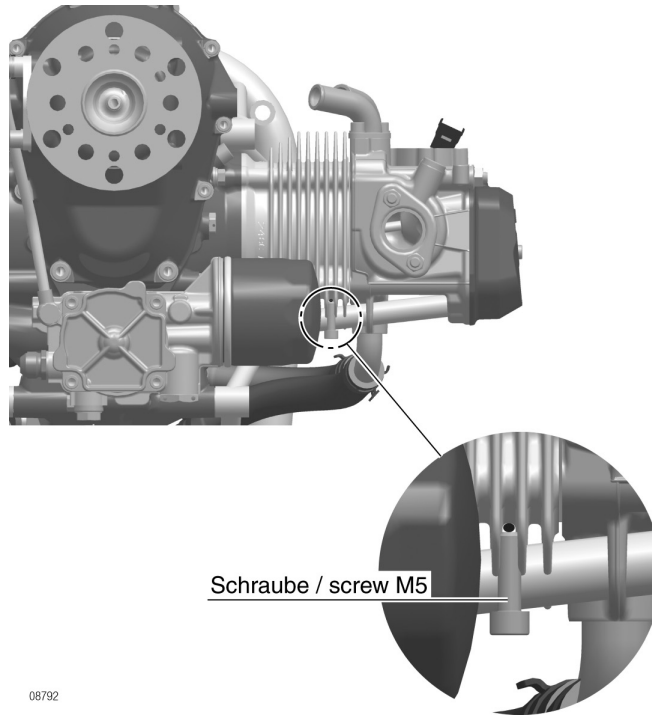

Fig. 10

**BRP-Powertrain**  
INSTALLATION MANUAL

**4.2.1) General notes on the cooling air ducts**

Front installation



Non-compliance can result in serious injuries or death! Certification according to the latest regulations, such as FAR or EASA, must be conducted by the aircraft or fuselage manufacturer.

For front installation in a closed cooling, ducting of cooling air to the cylinders is available. This removes the need for costly horizontal partitioning (baffles).

**NOTE:** It also means that the engine remains completely on the warm side of the engine compartment and is very easy to access. In special cases a separate cold air supply to the air filters must be provided.

BRP-Powertrain has developed a non-certified cooling air duct especially for this application. Cooling air ducts are not required if the cylinder temperature is within limit, see section 4.2).

Selecting cooling air ducts

The following recommendations should assist the aircraft or fuselage manufacturer in selecting suitable cooling air ducts.

<b>Cooling capacity</b>	The cooling air ducts must be designed such that they transfer thermal energy of approx. 6 kW (5.7 BTU/s) at take-off performance.
<b>Cross section of air duct</b>	Cross section of air duct under the airflow baffle min. 100 cm <sup>2</sup> (15.50 in <sup>2</sup> ).
<b>Material</b>	Glass fibre reinforced plastic or heat and fire resistant material.
<b>Attachment options</b>	Formlocking on engine block and mounting above the cylinder and the crankcase.  HINWEIS: If formlocking attachment is not sufficient, additional attachment is possible using two M8 threaded lugs on the top of the engine block.

**NOTICE**

The stated maximum permissible loads (per screw) are valid only if using the minimum specified thread length, and must never be exceeded.

Thread height 18 mm (0.71 in.).



# BRP-Powertrain

## INSTALLATION MANUAL

### Permissible loads (per screw)

	x-axis	y-axis	z-axis
Attachment points	-300 mm (-11.81 in.)	-30 mm (-1.18 in.)	-14 mm (-0.55 in.)
	-300 mm (-11.81 in.)	-30 mm (-1.18 in.)	-14 mm (-0.55 in.)

	Attachment points
Max. permissible force (safe load) in (N) on x, y and z axis	2000 N (449.62 lb-force)
Max. permissible bending moment (safe load) in (Nm) in x, y and z axis	50 Nm (36.89 lbft)
Min. length of thread (mm)	15 mm (0.59 in.)

### 4.3) Data for optional components of cooling system

Overflow bottle See Fig. 11 to Fig. 13.

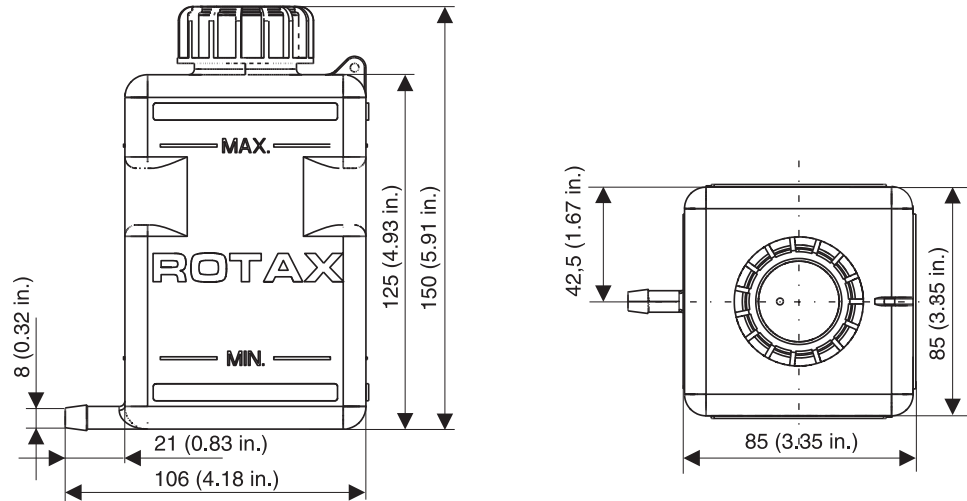

Fig. 11

09148

d05785.fm

**BRP-Powertrain**  
**INSTALLATION MANUAL**

**| Radiator**

Weight: see chap. 72-00-00 section: 2.1)

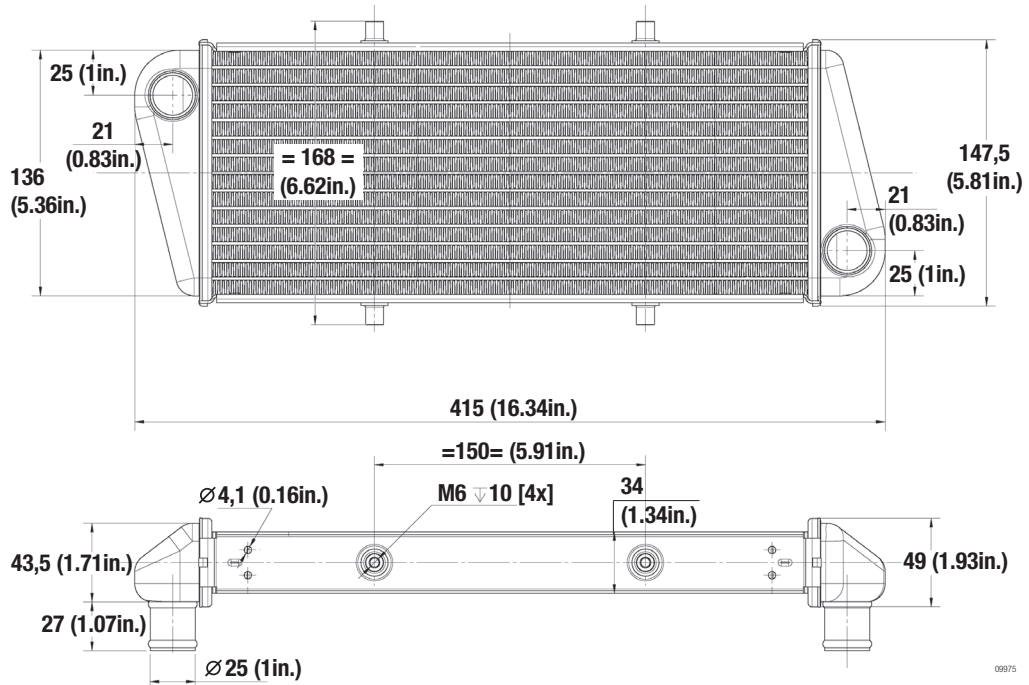

*Fig. 12*

**Cooling air duct**

Weight: see chap. 72-00-00 section: 2.1)

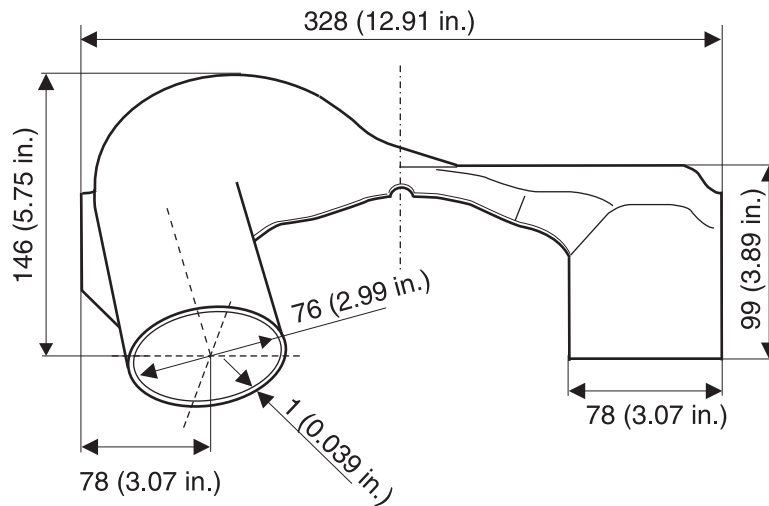

*Fig. 13*

09165

d05785.fm

**BRP-Powertrain**  
INSTALLATION MANUAL

**Chapter: 76-00-00**  
**ENGINE MANAGEMENT**

**Introduction**      The main components of the EMS are:

- ECU
- ECU actuators
- ECU sensors
- EMS current supply
- FUSE BOX
- Switches
- Wiring

**Table of contents**      This section of the Installation Manual describes the management of the aircraft engine.

Subject	Page
ECU	<a href="#">Page 5</a>
Technical data	<a href="#">Page 5</a>
Connector	<a href="#">Page 6</a>
Connections	<a href="#">Page 6</a>
Installation of the engine control unit assy.	<a href="#">Page 6</a>
FUSE BOX assy.	<a href="#">Page 7</a>
Technical data	<a href="#">Page 7</a>
Connections	<a href="#">Page 8</a>
Fitting the AMP connector	<a href="#">Page 8</a>
Installation position of the FUSE BOX assy.	<a href="#">Page 9</a>
Ambient air, pressure, temperatur sensor (AAPTS)	<a href="#">Page 11</a>
Maintenance tool	<a href="#">Page 11</a>
Pin assignment of maintenance and diagnostic interface	<a href="#">Page 11</a>
Display	<a href="#">Page 13</a>
Pin assignment of display interfaces	<a href="#">Page 13</a>

The core of the EMS is the engine control unit (ECU), which consists of two modules. These modules will be denoted by LANE A and LANE B, each one capable of taking over control, regulation and monitoring of the engine. In error-free engine operation, both LANES are turned ON. During engine control by LANE A, LANE B ensures that the engine operation can be maintained even after a failure or reduced functionality of LANE A. Depending on the activity and the failure status of the two LANES, the ECU automatically selects a LANE to take over control of the engine.

d05786.fm

# BRP-Powertrain

## INSTALLATION MANUAL

A huge quantity of sensors (e. g. sensors for measuring the pressure in the airbox) and actuators (e. g. ignition coils) of the engine is designed with redundancy. In this case, each of the sensors or actuators is connected to a LANE, so that the two LANES have the same measurement values and send the same output signals. Non-redundant sensors (e. g. oil pressure sensors) are connected to one LANE only and serve for the expanded monitoring of the engine functionalities. Due to an ECU internal communication, these sensor values will be exchanged between the two LANES (assuming that both LANES are active and free of errors).

Each LANE has a maintenance and a display interface (CAN-bus). While the maintenance interface is required to work with the software B.U.D.S. Aircraft to perform various diagnostic and maintenance activities, the display CAN interface enables the connection of a display for visualization of engine parameters.

In addition to the ECU, the FUSE BOX is another major component of the EMS. The FUSE BOX with its two rectifier regulators and generators (generator A and generator B) is responsible for a constant power supply to all EMS components including fuel pump modul and the aircraft.

After engine start and before the engine has reached a defined speed for a specified time (see latest Operators Manual), the EMS is powered by generator B. After this threshold is exceeded, the generator B can be used to supply the aircraft and to recharge the aircraft battery. In this system state generator A supplies the EMS. In case of an error in the area of the power supply, the EMS is re-switching to generator B for continuation of the engine operation. In this case, the aircraft is no longer supplied with power and the battery will not be recharged. This system state can only be reseted with a full restart of the ECU.

NOTE: The generator (generator A or generator B) always supplies the complete EMS (both LANES A and B). The assumption that generator A supplies LANE A and generator B supplies LANE B is false.

d05786.fm

# BRP-Powertrain

## INSTALLATION MANUAL

Overview

Engine control

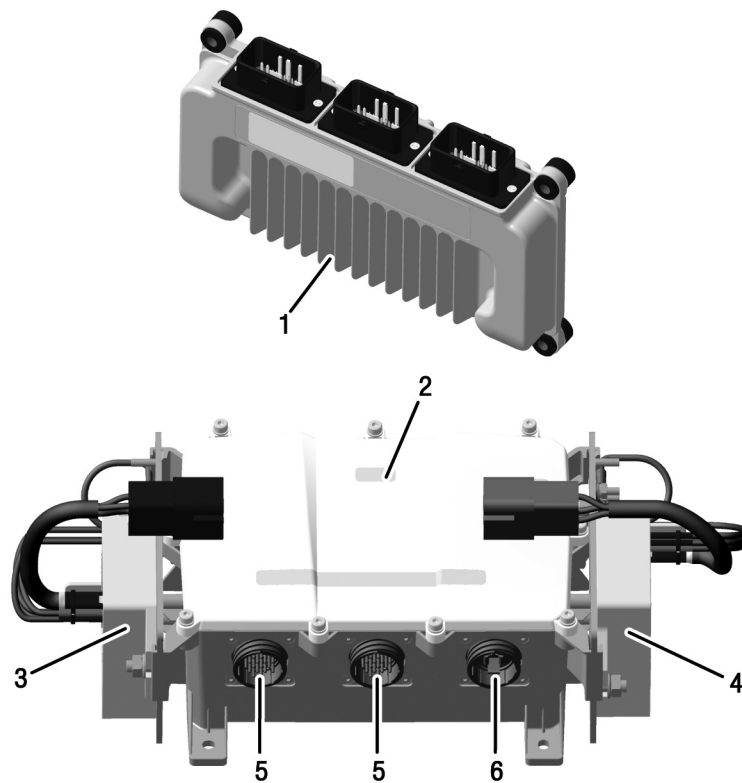

09550

Part	Function
1	Control unit assy. (ECU)
2	FUSE BOX assy.
3	Rectifier regulator A (black connector)
4	Rectifier regulator B (grey connector)
5	LANE A (X1)/ LANE B (X2) plug connection
6	Plug connection (X3)

Fig. 1

08725

d05786.fm

**BRP-Powertrain**  
INSTALLATION MANUAL

NOTES

**BRP-Powertrain**  
INSTALLATION MANUAL

**1) ECU**

**General**

There are two independent engine management units housed in a single waterproof box.

**1.1) Technical data**

See [Fig. 2](#).

**Graphic**

Connections and dimensions

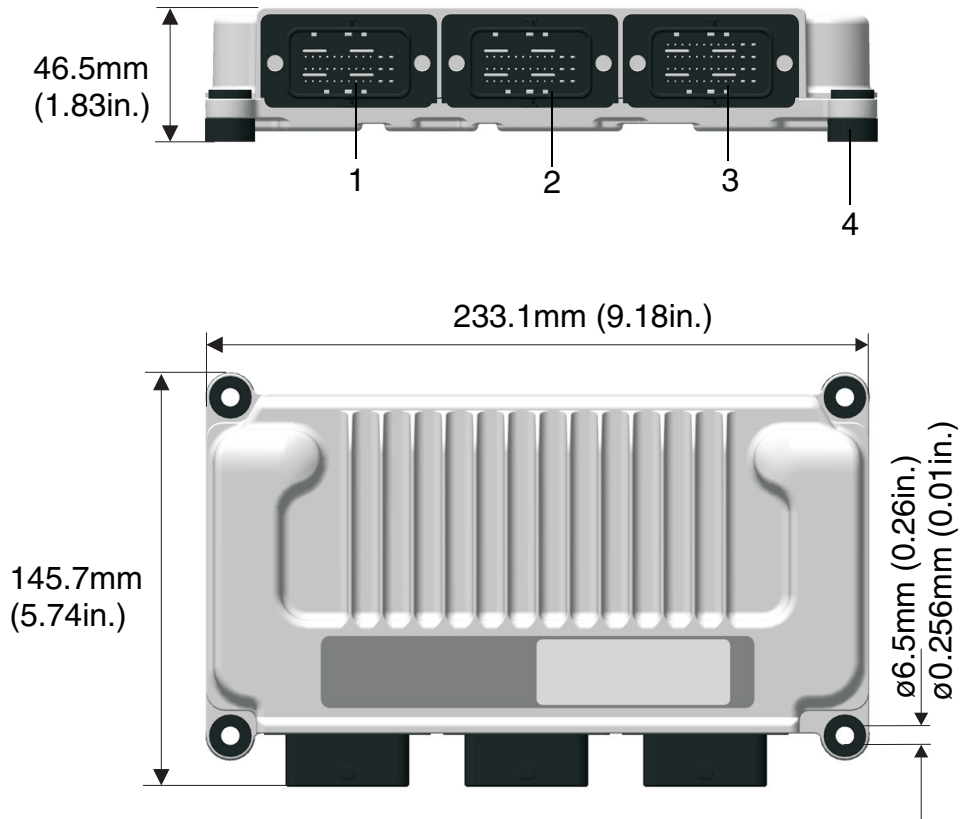

Part	Function
1	Plug connection A1
2	Plug connection A2
3	Plug connection B
4	Rubber vibration damping/insulation material

*Fig. 2*

06328

d05786.fm

**BRP-Powertrain**  
INSTALLATION MANUAL

## 1.2) Connector

Connector

**NOTICE**

The connectors are indexed, i.e. connector A1 can only be connected to A1. Excessive force or incorrect positioning can result in bent pins and the ECU would then need to be replaced.

---

## 1.3) Connections

Connection

Insert the wiring harness plug in the correct position on the ECU.

**NOTICE**

The rubber vibration damping (insulation material) must not be removed. If the rubber dampers were removed, the engine ground and the aircraft ground would be short-circuited.

---

## 1.4) Installation of the engine control unit (ECU)

Installation position

The ECU must be housed in the cockpit. It must not be installed in the engine compartment.

**NOTICE**

To prevent ingress of liquid (moisture), the ECU must be mounted so, that the plug connectors are facing downwards to the wiring harness.

- Installation position of the ECU: vertical/horizontal
  - Isolated - No connection to the airframe or engine
  - Cables or engine ground must not touch the ECU
  - Max. bending radius from the wiring harness 50 mm (1.97 in.)
  - Strain relief from wiring harness: ~ 100 mm (3.94 in.) behind the ECU connector
- 

ECU  
General note

- Unplug the ECU connector from the wiring harness only if absolutely necessary
  - In case of damage on the connector plug from the ECU: Replace wiring harness
  - Corrosion of the plug contacts: Replace wiring harness and ECU
  - Damaged connector plug locking pins: Replace ECU
  - Do not rebend the plug contacts of the ECU: Replace ECU if necessary
  - Connector plugs (ECU) are suitable for up to 20 plug-in operations according to the manufacturers information. The number of plugging operations must be entered into the logbook
- 

Temperature

Permissible component temperature: Max. +80 °C (176 °F)

---

Effectivity: 912 i Series  
Edition 1/Rev. 2

**76-00-00**



**BRP-Powertrain**  
INSTALLATION MANUAL

**2) FUSE BOX assy.**

**2.1) Technical data**

Graphic See [Fig. 3.](#)  
Connections and dimensions

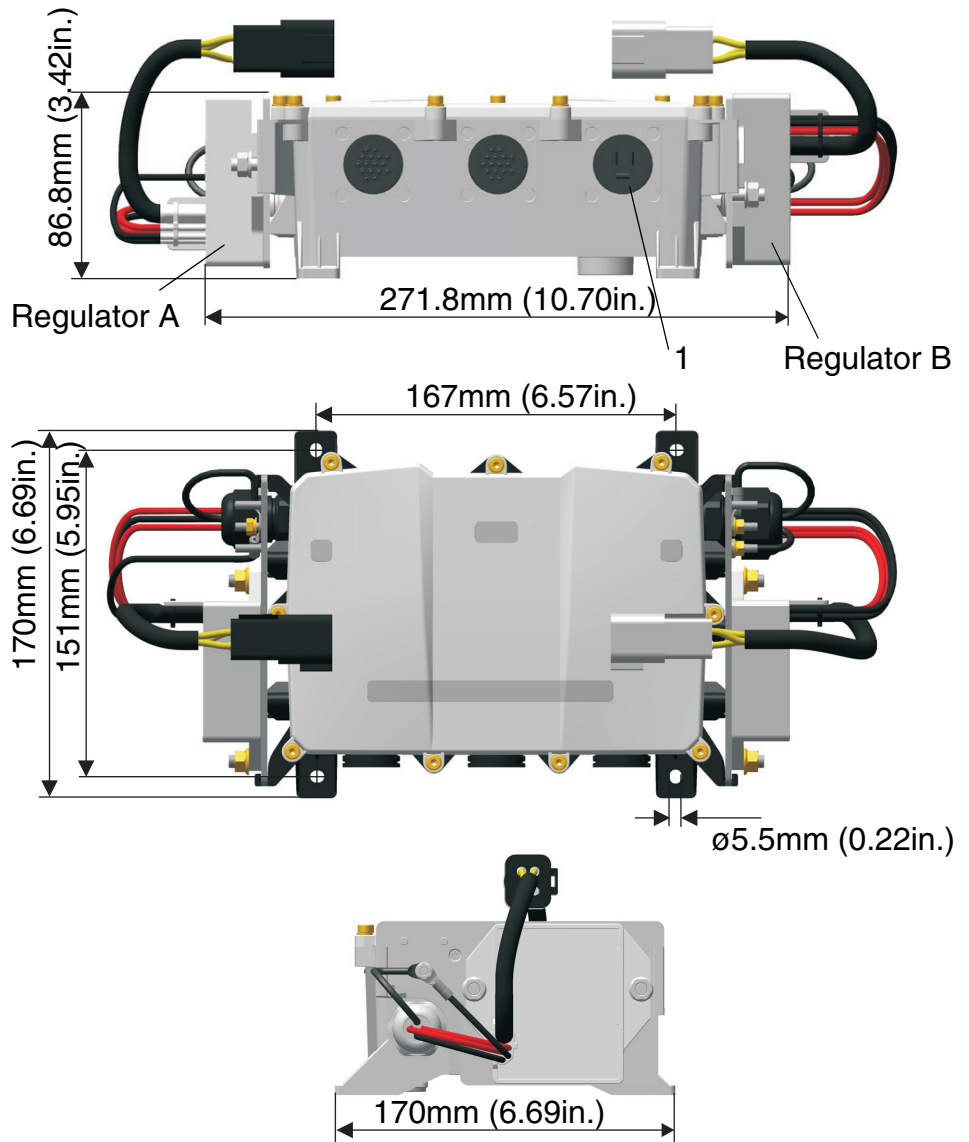

*Fig. 3*

06330

d05786.fm

**BRP-Powertrain**  
INSTALLATION MANUAL

**2.2) Connections**

**Connection**

See Fig. 4.

Seals supplied with the fuse box assy., must be inserted into the grooves provided for each connector plug.

Insert the wiring harness plug in the correct position on the FUSE BOX assy.

The mating plug for the FUSE BOX is included in the scope of delivery.

NOTE: A set of spare fuses can be found in the FUSE BOX.

**Graphic**

X3 connector

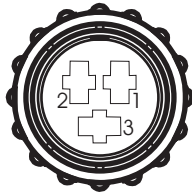

PIN 1 backup battery switch  
PIN 2 start power switch  
PIN 3 start power switch

Fig. 4

06393

The mating connector (AMP connector) for the FUSE BOX is included in the scope of supply.

**2.3) Fitting the AMP connector**

**General note**

See Fig. 5.

NOTE: The AMP connector is included in the scope of delivery.

**Special tools**

The following special tools and equipment are necessary for fitting the AMP connector.

Part number	Description
n.a.	Crimping pliers TYCO-Connectivity 69710-1
n.a.	Tool TYCO-Connectivity 90145-1
n.a.	Disassembly tool TYCO-Connectivity 91124-1

**Procedure**

Fitting the AMP connector:

Step	Procedure
1	Feed line (1) through the connector receptacle (5), squeeze plate (6) and cable holder (7).
2	Strip insulation from line (1).
3	Install socket contact (2) using suitable crimping pliers.
4	Push the socket contact (2) into the appropriate position in the AMP connector (3) until it engages.

d05786.fm

**BRP-Powertrain**  
INSTALLATION MANUAL

Step	Procedure
5	Check for tight fit.
6	Install strain relief clamp (4).

**Graphic**

Fitting the AMP connector

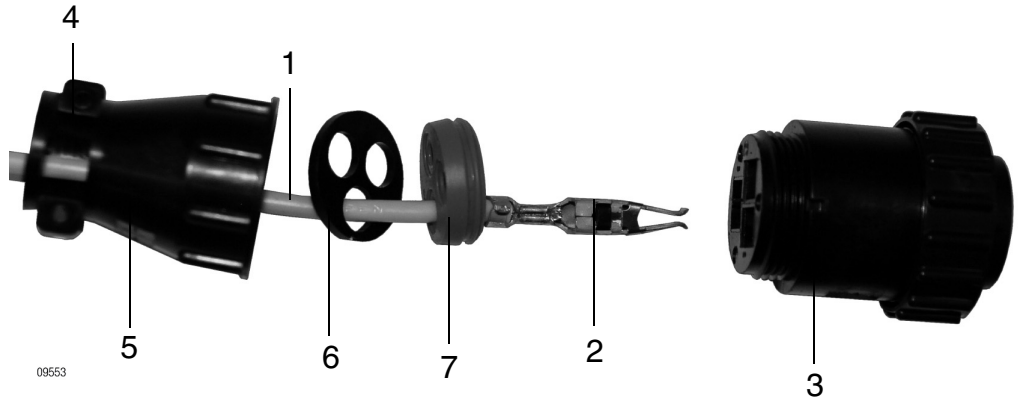

Part	Function
1	Line
2	Socket contact
3	Connector
4	Strain relief clamp
5	Connector receptacle
6	Squeeze plate
7	Cable holder

*Fig. 5*

**2.4) Installation position of the FUSE BOX assy.**

The FUSE BOX must be placed that the maximum permissible component temperature must not exceed.



**WARNING**

The FUSE BOX must not be installed in the cockpit.  
Installation in the engine compartment ONLY!

**Temperature**

Permissible component temperature: Max. +80 °C (176 °F)

**BRP-Powertrain**  
INSTALLATION MANUAL

NOTES

d05786.fm

### 3) Ambient air, pressure, temperature sensor (AAPTS)

**General**

The AAPTS sensor is the all-in-one sensor for engine ambient temperature and engine ambient pressure. In cowled engine installations it has to be mounted in the engine compartment in a ram air free area and close to the air inlet. The sensor should measure the correct air inlet temperature and the air pressure right before the air filter.

**NOTICE**

The AAPTS sensor should not be mounted in the air intake system between the air filter and throttle body.

### 4) Maintenance tool

**General**

For engines of the ROTAX 912 i Series, the maintenance and diagnostic software B.U.D.S. Aircraft is available. This provides not only the reading of ECU logs, it also provides a variety of functionalities to support troubleshooting of the engine. To start this software and connect the engine with a computer a B.U.D.S. Aircraft kit is required. This is a USB adapter, that provides different software functionalities depending on its version.

#### 4.1) Pin assignment of maintenance and diagnostic interface

**Pin assignment**

See [Fig. 6](#).

Pin assignment for Sub-D DE9 (9-pin) of maintenance and diagnostic interface.

Pin	Description	HIC Pin no.	Sub-D DE9 Pin no.
LANE A Sub-D DE9 Maintenance and Diagnostic interface	CAN_LOW_2_A	11 (HIC A)	2
	CAN_GND_2_A	10 (HIC A)	3
	CAN-HIGH_2_A	12 (HIC A)	7
LANE B Sub-D DE9 Maintenance and Diagnostic interface	CAN_LOW_2_B	15 (HIC B)	2
	CAN_GND_2_B	14 (HIC B)	3
	CAN_HIGH_2_B	16 (HIC B)	7

**NOTE:** The positions of the individual pins on the 9-pin Sub-D DE9 connector are numbered.

**NOTE:** It is recommended not to connect maintenance and diagnostic interfaces LANE A and LANE B together.

**Impedance**

If the ECU is connected with the Maintenance and Diagnostic Sub-D DE9 DE9 (9-pin) connector, the impedance between CAN\_HIGH\_2\_A (CAN\_HIGH\_2\_B) and CAN\_LOW\_2\_A (CAN\_LOW\_2\_B) will be ~60 Ohm.

**BRP-Powertrain**  
INSTALLATION MANUAL

NOTES

**5) Display**

Indicating instruments



**WARNING** Non-compliance can result in serious injuries or death! Only use display instruments, which have two separate CAN Aerospace interfaces and can work separately. The CAN Aerospace interfaces of LANE A and B must not be connected, otherwise the redundancy of the display instrument is no longer given.

Only use display devices that have a CAN Aerospace interface. For instruments and data of the CAN Aerospace protocol, contact an authorized distributor- or Service Center for ROTAX aircraft engines.

**NOTE:** Only the defined operating limits by ROTAX (see latest Operators Manual) are valid for engine operation. The responsibility for adapting these operating limits to the display accordingly is up to the display manufacturer .

**5.1) Pin assignment of display interfaces**

Display pin assignment

See [Fig. 6.](#)

**Pin assignment of display interfaces)**

Pin	Description	HIC Pin no.	Pin no. on display
LANE A Sub-D DE9 Display interface	CAN_LOW_1_A	5 (HIC A)	Refer to the connection specifications of the display manufacturer.
	CAN_GND_1_A	4 (HIC A)	
	CAN-HIGH_1_A	6 (HIC A)	
LANE B Sub-D DE9 Display interface	CAN_LOW_1_B	7 (HIC B)	
	CAN_GND_1_B	6 (HIC B)	
	CAN_HIGH_1_B	8 (HIC B)	



**NOTICE** In order to ensure a high electromagnetic compatibility in data transmission, twisted cables (3 pins: CAN\_H, CAN\_L, CAN\_GND) must be used for the CAN-connections.

## BRP-Powertrain

### INSTALLATION MANUAL

NOTE:

If both CAN-interfaces are connected together and plugged to an indicating instrument with only one Input, an error on one of the interfaces can occur or a short circuit on the data management can cause that no more data can be supplied to the indicating instrument.

Accordingly the pilot has no longer important information, such as temperature, oil pressure, boost pressure and speed available.

---



# BRP-Powertrain INSTALLATION MANUAL

## Graphic

## Wiring HIC-Maintenance und Display

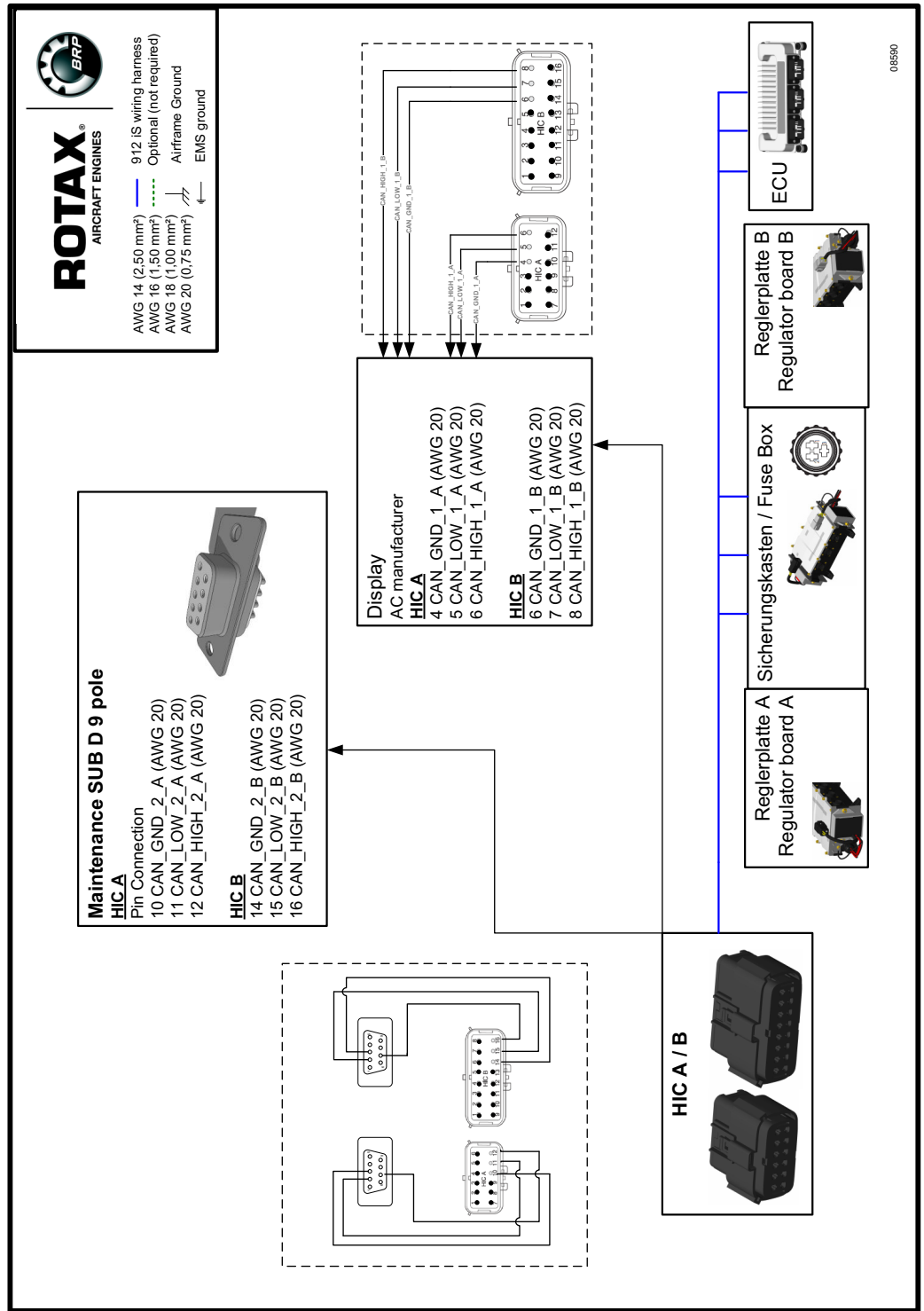

Fig. 6

08590

d05786.fm

**BRP-Powertrain**  
INSTALLATION MANUAL

NOTES

**Chapter: 78-00-00**  
**EXHAUST SYSTEM**

**General note** See [Fig. 1](#).

**NOTICE**

The exhaust system must be designed by the aircraft or fuselage manufacturer such that the permissible loads and bending moments on the points of attachment are not exceeded. The exhaust system may require additional support.

**Table of contents** This section of the Installation Manual contains information on the exhaust system of the aircraft engines.

Subject	Page
General notes on the exhaust system	<a href="#">Page 3</a>
Exhaust system requirements	<a href="#">Page 5</a>
Technical data	<a href="#">Page 5</a>
If a GENUINE-ROTAX exhaust is not in use	<a href="#">Page 5</a>
Attaching the exhaust system	<a href="#">Page 7</a>
Dimensions of the exhaust system	<a href="#">Page 9</a>
Exhaust system assy.	<a href="#">Page 9</a>
Data for optional components of the exhaust system	<a href="#">Page 11</a>

# BRP-Powertrain

## INSTALLATION MANUAL

### Overview

### Exhaust system, typical

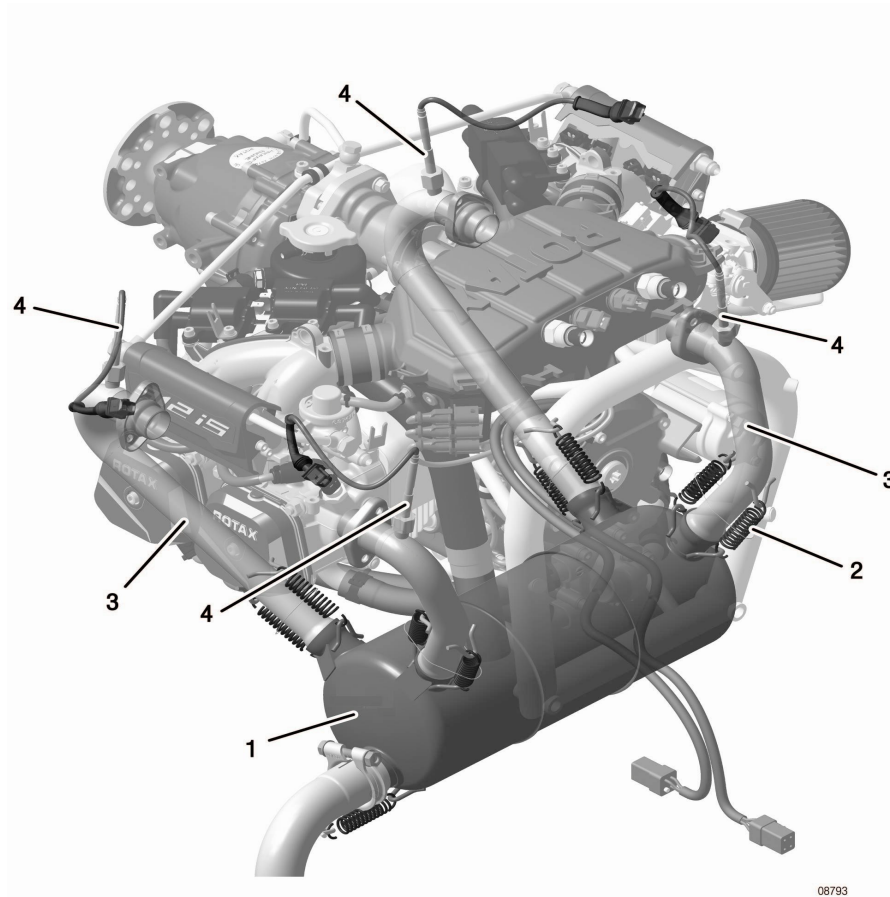

Part	Function
1	Muffler
2	Tension spring
3	Exhaust pipe
4	EGT temperature sensor

Fig. 1

# BRP-Powertrain

## INSTALLATION MANUAL

### 1) General notes on the exhaust system

**Certification** An exhaust system especially designed for universal application has been developed by BRP-Powertrain. Certification according to the latest regulations, such as FAR or EASA, must be conducted by the aircraft or fuselage manufacturer.

**NOTICE**

Vibrations due to improper installation and maintenance is the most common reason for damage of the exhaust system.

---

#### 1.1) The following recommendations should help the aircraft or fuselage manufacturer to select a suitable exhaust system.

**Damping element** The ideal is a common transversal damping element serving all 4 cylinders, positioned under the engine.

**NOTE:** Equal length of pipes from the cylinder to damping element is recommended for better tuning.

---

**Distribution of the exhaust system** Distribution of the exhaust system into 2 separate systems is not recommended. Individual mufflers on either side cause power loss and increased engine noise.

---

**Exhaust flange** During assembly, ensure that the flange is parallel to the cylinder head flange and is not protruding.

**NOTE:** Tighten the exhaust flange evenly and in parallel. There must be a gap of the same size all the way round.

---

**Oil filter** There must be a clearance of at least 20 mm (0.79 in.) between the exhaust pipe and the oil filter to allow the oil filter to be fitted and removed without having to slacken off the exhaust system. If a heat shield is fitted, this will also have to be taken into consideration.

**NOTICE**

The exhaust system must not adversely affect the operation or replacement of the oil filter.

**BRP-Powertrain**  
INSTALLATION MANUAL

Graphic

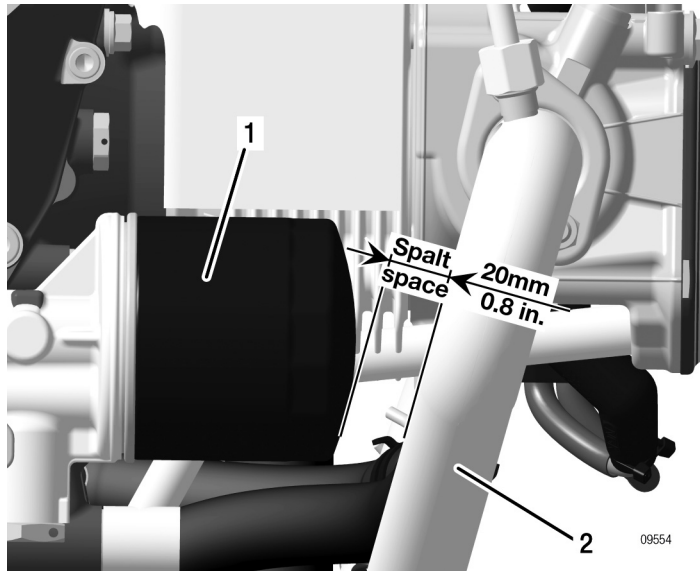

Part	Function
1	Oil filter
2	Exhaust manifold

*Fig. 2*

## 2) Exhaust system requirements

**General note** See Fig. 4 and Fig. 5.

**⚠ WARNING**

Non-compliance can result in serious injuries or death!

The exhaust system must be designed and built so that the permissible operating temperatures are maintained and the max. exhaust gas temperatures are not exceeded.

**NOTICE**

Install heat shields in required areas (fuel, oil, coolant hoses or tubes) and/or on the electronic components. Because of the high temperatures, provide suitable protection against accidental contact.

**NOTICE**

Secure exhaust system by suitable means according to installation requirements (Lockwire, heat-resistant silicone to dampen the exhaust spring etc.).

**NOTICE**

The performance specifications relate to ISA (15 °C (59 °F)) conditions and are only achieved if the engine is equipped with an unmodified GENUINE-ROTAX exhaust system and airbox.

---

### 2.1) Technical data

- Average radius of exhaust manifold: at least 40 mm (1.57 in.)
- Inner diameter of manifold pipe: at least 28 mm (1.10 in.)
- Damping volume: approx. 5 l (1.32 US gal)
- Back pressure at maximum power: max. 0.2 bar (2.9 psi) measured in each case approx. 100 mm (3.94 in.) beyond the end of the exhaust flange

---

### 2.2) If a GENUINE-ROTAX exhaust is not in use

**General note** The four supplied exhaust sockets with exhaust flange and lock nuts must be used.

Exhaust sockets material: X6CrNiMoTi 17 12 2 (DIN 1.4571)

Tightening torque of M8 lock nuts: min. 15 Nm (133 in.lb.)

**NOTE:** The exhaust flange must not touch the cylinder head.

**BRP-Powertrain**  
INSTALLATION MANUAL

Graphic

Exhaust sockets

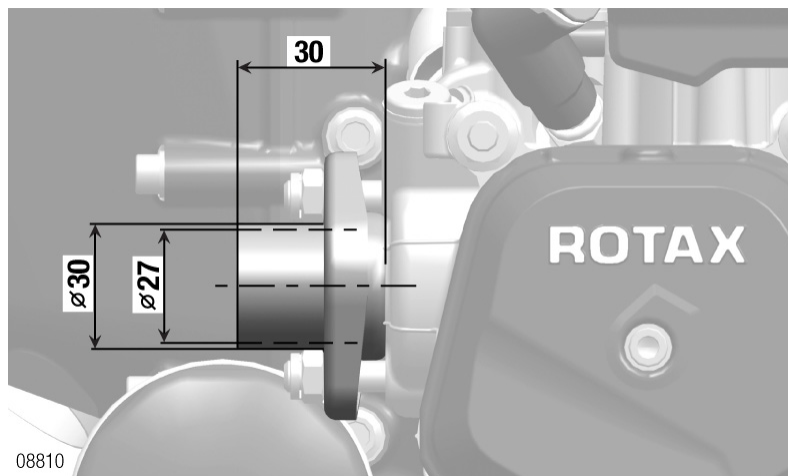

*Fig. 3*

08810



# BRP-Powertrain

## INSTALLATION MANUAL

### 3) Attaching the exhaust system

#### General note

The shape and configuration of the exhaust system is essentially determined by the free space available in the aircraft.

Two M8x23 studs are provided on each cylinder for attaching the exhaust system.

#### Location of the studs

NOTE: All dimensions from zero reference point (P).

Location	Coordinates		
	x axis mm/in.	y axis mm/in.	z axis mm/in.
Cylinder 1	-160/-6.3	-196/-7.72	-82/-3.23
	-160/-6.3	-212/-8.35	-113/-4.45
Cylinder 2	-192/-7.56	196/7.72	-82/-3.23
	-192/-7.56	212/8.35	-113/-4.45
Cylinder 3	-408/-16.06	-196/-7.72	-82/-3.23
	-408/-16.06	-212/-8.35	-113/-4.45
Cylinder 4	-438/-17.24	196/7.72	-82/-3.23
	-438/-17.24	212/8.35	-113/-4.45

	Attachment points
Max. permissible forces (safe load) in (N/lb-force) on x, y and z axis	1000/224.81
Max. permissible bending moment (safe load) in (Nm/ft.lb) on x, y and z axis	40/30

**BRP-Powertrain**  
INSTALLATION MANUAL

NOTES

d05787.fm

## 4) Dimensions of the exhaust system

### 4.1) Exhaust system assy.

See Fig. 4 und Fig. 5.

Location and position of the temperature sensor

**NOTICE**

If the EGT sensor is fitted on a slope or with the sensor tip pointing upwards, then various fluids can lead to undesired corrosion. The sensor could then fail.

The axis of the temperature sensor may be inclined up to 75 ° from the vertical, so that any residual water will not be collected in the tip of the temperature sensor.

The sensor element itself has no particular orientation, it can be rotated 360° around the axis. The tip of the temperature sensor must be positioned free in the gas flow.

Position

Approx. 50 mm (1.97 in.) from the cylinder head flange i.e. measured from the flat surface on the cylinder head to encoder axis. It is important that all 4 temperature sensors are placed at the same distance!

Graphic

Position

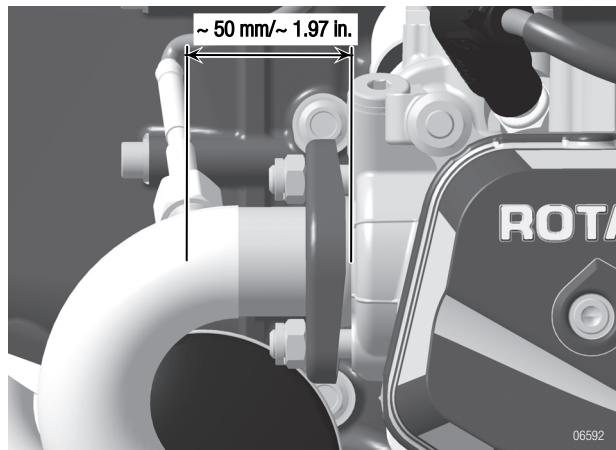
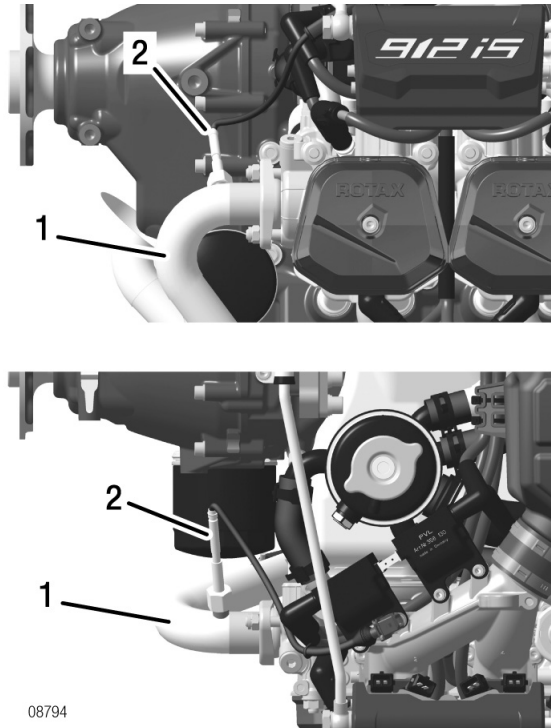

Fig. 4

**BRP-Powertrain**  
INSTALLATION MANUAL

**Graphic** Exhaust gas measurements



Part	Function
1	Exhaust manifold
2	EGT sensor

*Fig. 5*

---

**Operating limit** See the current 912 i Series Operators Manual.

---

**BRP-Powertrain**  
INSTALLATION MANUAL

**4.2) Data for optional components of exhaust system**

**Weight** See chap. 72-00-00 section: 2.1).  
**Graphic** Exhaust elbow

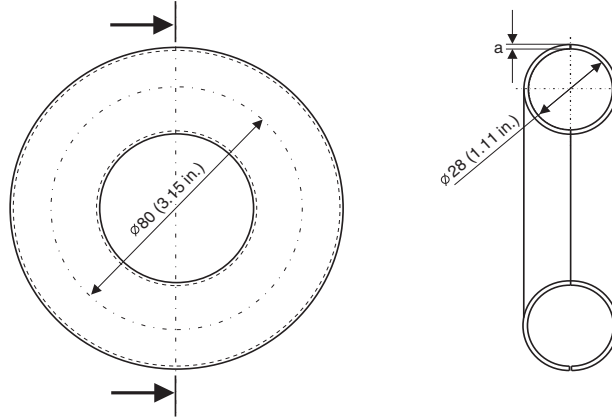

**Material/strength:** X 15 CrNiSi20-12 (DIN 1.4828) (309 stainless steel) a = 1.5 mm (0.06 in.)

*Fig. 6*

09164

**Graphic** Muffler

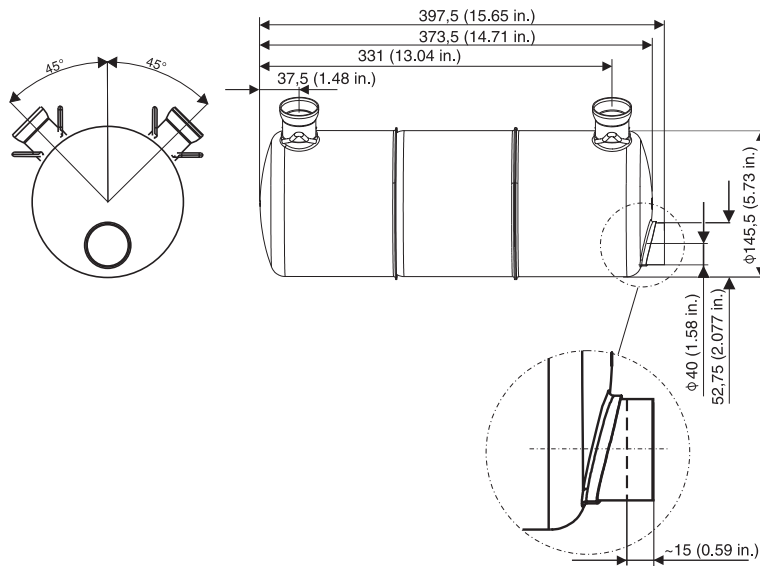

**Material/strength:** X 6CrNi 189 (DIN 1.4541) (321 stainless steel) a = 1 mm (0.04 in.)

*Fig. 7*

06996

d05787.fm

**BRP-Powertrain**  
INSTALLATION MANUAL

Graphic

Tailpipe

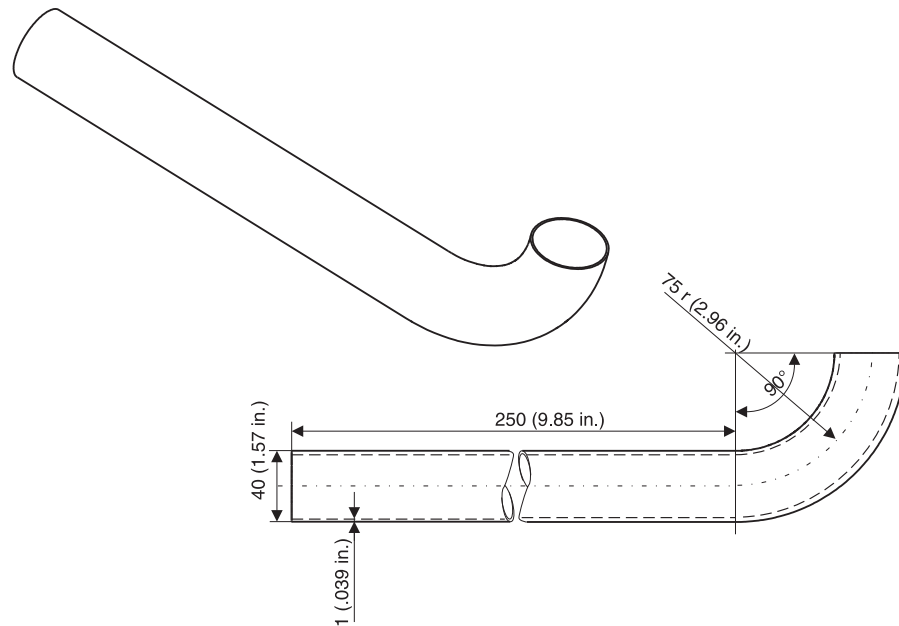

**Material/strength:** X 5CrNi 189 (DIN 1.4301) (304 stainless steel)  
a = 1 mm (0.04 in.)

*Fig. 8*

09153

Graphic

Ball joint (male)

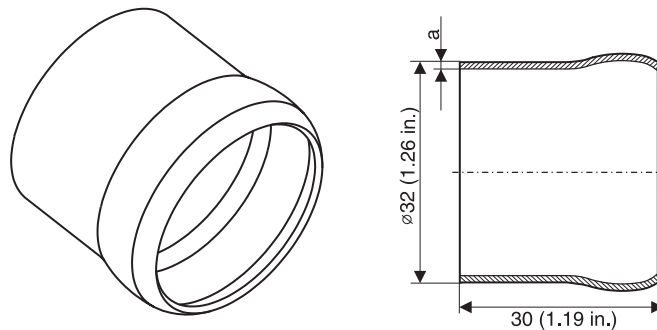

**Material/strength:** X 15CrNiSi 20, 12 (DIN 1.4301) (304 stainless steel)  
a = 1 mm (0.04 in.)

*Fig. 9*

09166

**BRP-Powertrain**  
INSTALLATION MANUAL

Graphic

Exhaust pipe

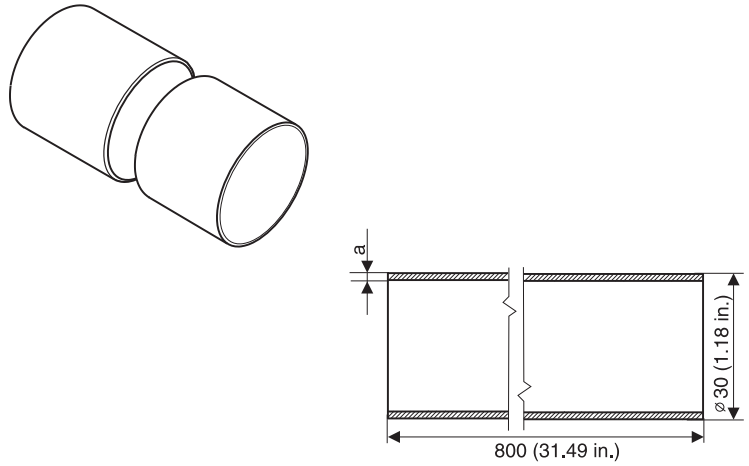

**Material/strength:** X 15CrNiSi 20, 12 (DIN 1.4301) (304 stainless steel)  
a = 1 mm (0.04 in.)

*Fig. 10*

09167

**BRP-Powertrain**  
INSTALLATION MANUAL

**Graphic** Exhaust system assy., typical

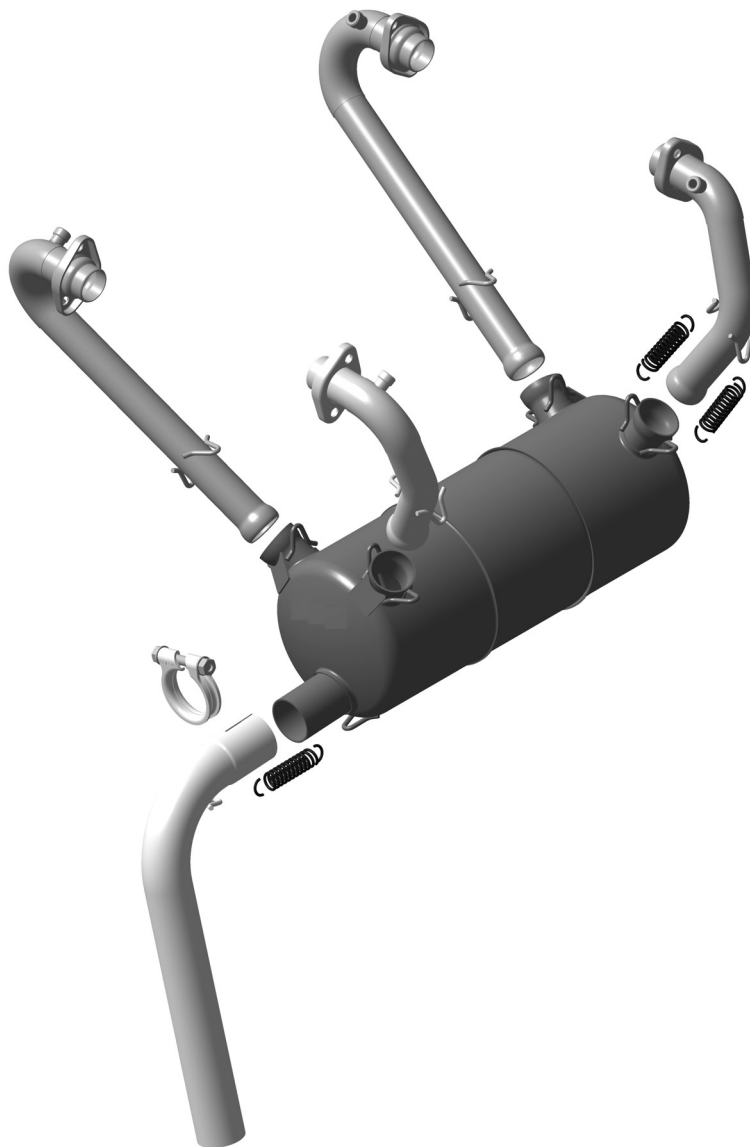

*Fig. 11*

05913



**BRP-Powertrain**  
INSTALLATION MANUAL

**Chapter: 79-00-00**  
**LUBRICATION SYSTEM**

**General note** The ROTAX 912 i Series is fitted with a dry sump forced lubrication system with an oil pump and integrated pressure regulator.

**Table of contents** This section of the Installation Manual describes the system, operating limits and requirements for the lubrication system.

Subject	Page
Lubrication system (oil system)	<a href="#">Page 3</a>
System description	<a href="#">Page 3</a>
Operating limits	<a href="#">Page 4</a>
Checking the oil circuit	<a href="#">Page 5</a>
Measuring of the vacuum	<a href="#">Page 7</a>
Oil and purging line requirements	<a href="#">Page 9</a>
Connecting sizes and position of connections	<a href="#">Page 11</a>
Oil circuit	<a href="#">Page 11</a>
Oil tank	<a href="#">Page 13</a>
Permissible position and location of the oil tank	<a href="#">Page 16</a>
General notes on the oil cooler	<a href="#">Page 19</a>
Permissible position and location of the oil cooler	<a href="#">Page 19</a>
Capacity	<a href="#">Page 20</a>
Purging the lubrication system	<a href="#">Page 21</a>
Checking the hydraulic valve tappet for correct purging	<a href="#">Page 24</a>
Replacement of components	<a href="#">Page 25</a>
Data for optional components of lubrication system	<a href="#">Page 27</a>
Oil cooler	<a href="#">Page 27</a>
Variants of connectors	<a href="#">Page 27</a>

**BRP-Powertrain**  
INSTALLATION MANUAL

**Overview**

Lubrication system

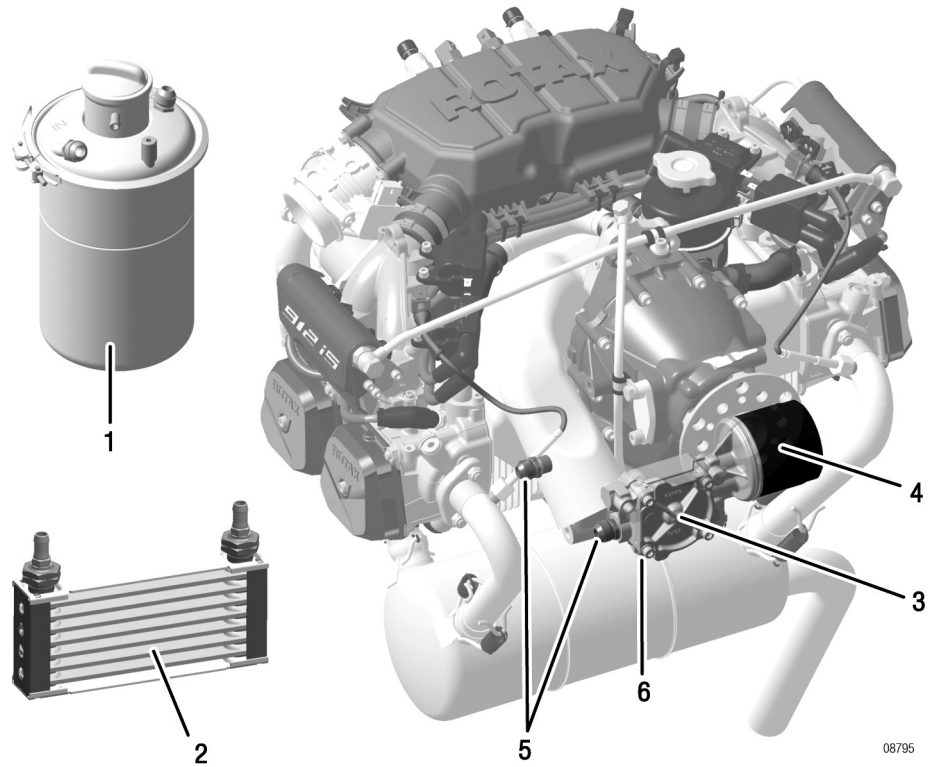

Part	Function
1	Oil tank
2	Oil cooler
3	Oil pump
4	Oil filter
5	Screw socket
6	Plug screw

*Fig. 1*

**NOTE:** The suction line can also be connected to the bottom of the oil pump housing. In this case, the plug screw and gasket ring are to be replaced by the screw socket and gasket ring. See the current 912 i Series Heavy Maintenance Manual.

a05398.fm

# BRP-Powertrain

## INSTALLATION MANUAL

### 1) Lubrication system (oil system)

#### 1.1) System description

**Drive** See Fig. 2.

**NOTE:** The oil pump is driven by the camshaft.

The main oil pump sucks the engine oil from oil tank (1) via the oil cooler (3) and forces it through the oil filter to the individual points of lubrication (also lubricates the propeller governor).

The surplus oil emerging from the points of lubrication accumulates on the bottom of the crankcase and is forced back to the oil tank by the crankcase blow-by gases.

---

**Purging** **NOTE:** The oil circuit is vented via nipple in the oil tank.

---

**Connections**



Non-compliance can result in serious injuries or death!

The oil cooler and its connections must be certified according to the latest regulations, such as FAR and EASA, by the aircraft or fuselage manufacturer.

Only the following connections need to be established to complete the lubrication system (oil system).

	Oil circuit, engine (main oil pump)
Connections from	Oil tank (outlet) to oil cooler
	Oil cooler to oil pump (inlet)
	Oil return to oil tank (inlet)
	Oil tank to purging line

**NOTE:** An oil tank is included with the standard engine version. No provision has been made for attachment of an oil cooler on the engine.

---

**BRP-Powertrain**  
INSTALLATION MANUAL

Graphic

Oil system

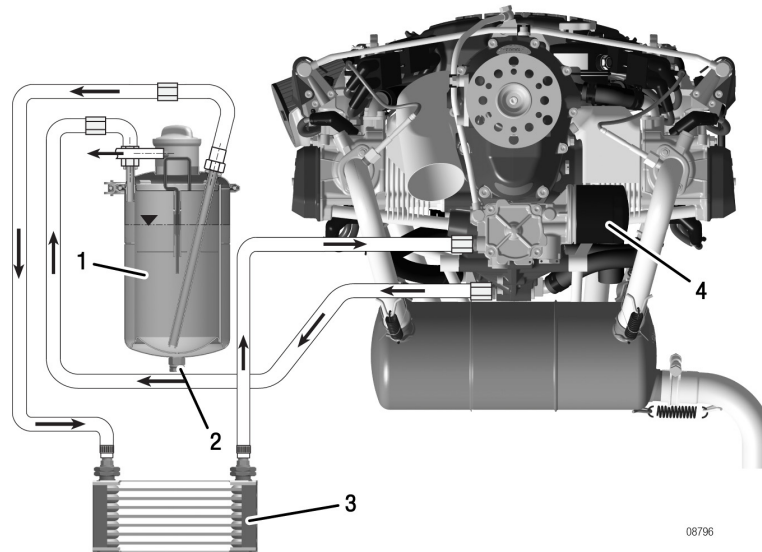

Part	Function
1	Oil tank
2	Oil drain screw
3	Oil cooler
4	Oil filter

*Fig. 2*

## 1.2) Operating limits

General note



Non-compliance can result in serious injuries or death!  
The lubrication system must be designed such that the permissible operating temperatures and maximum values are not exceeded.

Operating limits	Manual
Oil pressure	See OM 912 i Series, section 2.1
Oil temperature	See OM 912 i Series, section 2.1



Non-compliance can result in serious injuries or death!  
At operation below nominal temperature, formation of condensate in the oil system might negatively affect oil quality.

a05398.fm

## BRP-Powertrain

### INSTALLATION MANUAL

Low temperatures

**NOTE:** When operating at low temperatures, installation of an oil thermostat, parallel to the oil cooler is highly recommended.

**WARNING**

Non-compliance can result in serious injuries or death!

If an oil thermostat is being used and the ambient temperature is low, there is a possibility that the oil may congeal briefly when in a steep descent. Pay extra attention to the oil pressure and oil temperature during these abnormal conditions. If necessary, revert to a cruising or climb situation.

Advantages: safe oil pressure after cold start, prevention of fuel and water accumulation in the oil.

See SL-912-011 "Use of an oil thermostat", latest issue.

---

### 1.3) Checking the oil circuit

General note

See [Fig. 3](#).

**NOTE:** The required pressure gauges and connection parts are not included in the BRP-Powertrain delivery.

To check the oil circuit for correct function, the following readings have to be taken with the engine running.

Measurement of crankcase pressure

See [Fig. 3](#).

Measurement of the mean crankcase pressure at full throttle, this ensures correct oil return from crankcase (blow-by gas).

---

**NOTICE**

Do not remove the magnetic plug for prolonged periods nor during flight operations.

A pressure sensor (1) (pressure gauge with liquid damping) can be fitted instead of the magnetic plug (2) or the crankshaft locking screw (3). The magnetic plug (2) or the crankshaft locking screw (3) is removed and the pressure sensor (1) is fitted.

---

**BRP-Powertrain**  
INSTALLATION MANUAL

**Graphic**

Measurement of crankcase pressure

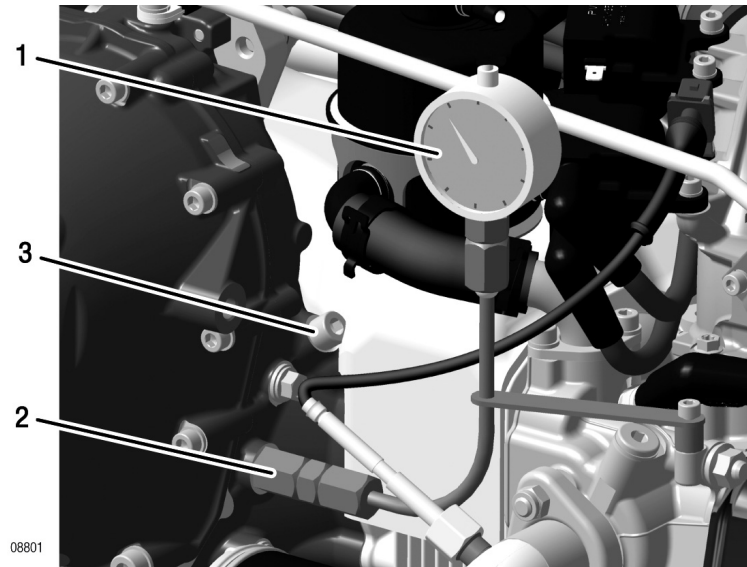

Part	Function
1	Pressure indicator
2	Magnetic plug
3	Crankshaft locking screw

*Fig. 3*

**Magnetic plug**

**NOTE:** The thread for the magnetic plug (2) must be M12x1.5 (metric) and M8 for the crankshaft locking screw (3) (use always new gasket).

**Pressure values**

The pressure in the crankcase at (full throttle) must not exceed the prevailing ambient pressure by more than 0.45 bar (6.53 psi) at 90 °C (194 °F) oil temperature.

**⚠ WARNING**

Non-compliance can result in serious injuries or death! If the readings exceed the pressure limits, then the flow resistance in the oil return line from oil sump to oil tank is too high in the current engine installation (contamination, restrictions of cross-section, etc.). This condition is unsafe and must be rectified immediately.

If crankcase pressure and measuring pressure of the vacuum readings and all operational data (flight attitude, temperatures, etc.) are within the specified limits, then it can be assumed that the oil circuit is working correctly.

a05398.fm

**BRP-Powertrain**  
INSTALLATION MANUAL

## 1.4) Measuring of the vacuum

**Measuring of the vacuum**

See [Fig. 4](#).

Measure the vacuum in the suction oil line (1) - from the oil tank via the oil cooler to the engine oil pump - at a distance of max. 100 mm (4 in.) from the oil pump suction connector (2).

At full throttle, the indicated vacuum (3) upstream of the oil pump must not be less than 0.3 bar (4.35 psi), otherwise the oil hose (1) could collapse and block the oil supply to the engine.

 **WARNING**

Non-compliance can result in serious injuries or death!

The vacuum (3) (pressure gauge with liquid damping) must be verified over the complete engine operation range. If the oil is cold, the flow resistance increases, which means that not enough oil will flow on the suction side.

---

**BRP-Powertrain**  
INSTALLATION MANUAL

Graphic

Measuring of the vacuum

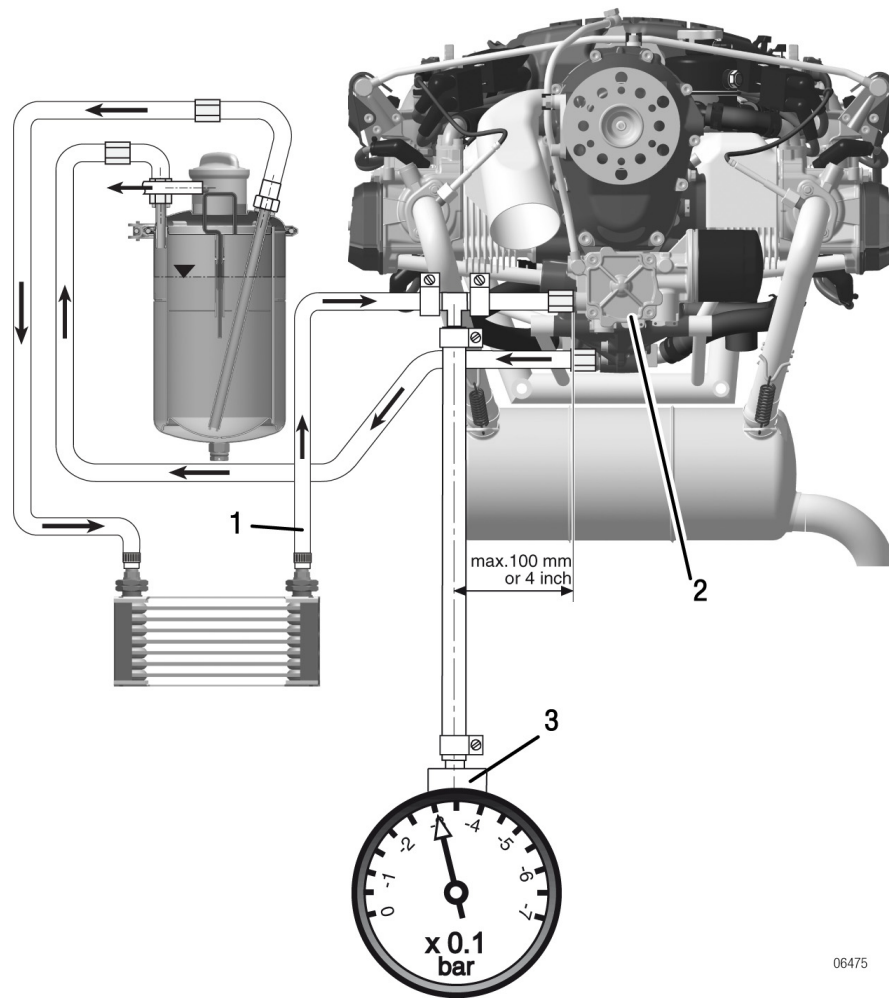

06475

Part	Function
1	Suction oil line
2	Oil pump
3	Pressure gauge

*Fig. 4*



# BRP-Powertrain

## INSTALLATION MANUAL

### 1.5) Oil and purging line requirements

#### Oil lines

#### Oil circuit, engine (main oil pump)

- Temperature durability: min. 140 °C (284 °F)
  - Pressure durability: min. 10 bar (73 psi.)
  - Bending radius: min. 70 mm\* (2.76 in.)  
\* unless otherwise stated by the hose manufacturer
  - Minimum inner dia. of oil lines in relation to total length
    - up to 1 m (39.37 in.) inner diameter minimum 11 mm (0.43 in.)
    - up to 2 m (78.74 in.) inner diameter minimum 12 mm (0.47 in.)
    - up to 3 m (118.11 in.) inner diameter minimum 13 mm (0.51 in.)
  - Length of individual oil line: max. 3 m (9.84 ft.)
- 

#### Purging line

#### Purging line of oil tank

See [Fig. 5](#).

- Route the line without kinks and avoid sharp bends.

NOTE: Water is a by-product of the combustion of fuel. Most of this water will dissipate from the combustion chamber with the exhaust gases.

A small amount will reach the crankcase and must be disposed of through the purging line.

- The purging line must be routed in a continuous decline or furnished with a drain bore at its lowest point to drain any condensate.
  - The purging line must be protected from any kind of ice formation from condensation, e.g. insulation protection or routing in a hose with hot air flow and furnishing the vent line with a bypass opening (1) before the cowling outlet (2).
-

**BRP-Powertrain**  
INSTALLATION MANUAL

Graphic

Purging line.

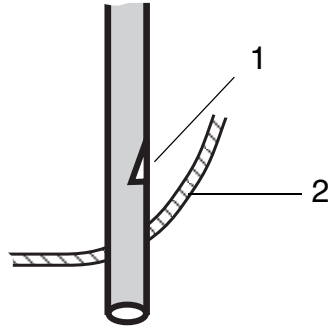

Part	Function
1	Bypass opening
2	Outlet through the cowling

*Fig. 5*

04874

**BRP-Powertrain**  
INSTALLATION MANUAL

## 2) Connecting sizes and position of connections

**General note**

**NOTICE**

Utilize the full slip-on length for all connections. Secure hoses with suitable screw clamps or crimp connections.

**NOTE:** The oil line connections are optionally available as UNF threads.

### 2.1) Oil circuit (engine)

**General note**

See Fig. 6.

Depending on engine configuration, the oil feed line connectors may vary:

- 912 iSc/iS thread M18 optional UNF thread

**Oil pump (inlet)**

Connection:

Oil pump (inlet)	
Screw socket (1)	3/4-16 UNF/M16x1.5
Tightening torque of inlet line	25 Nm (18.44 ft.lb.)

**Graphic**

Oil pump inlet

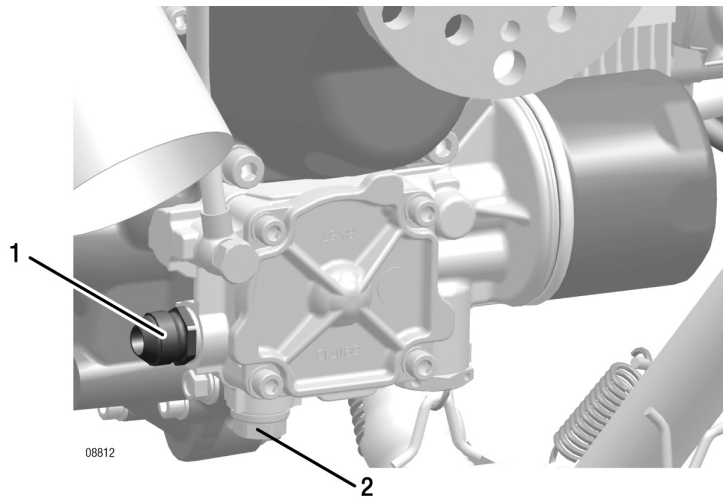

Part	Function
1	3/4-16 UNF/M16x1.5 screw socket
2	Alternative connection

*Fig. 6*

d05398.fm

**BRP-Powertrain**  
INSTALLATION MANUAL

**Oil return**

See [Fig. 7](#).

**NOTICE**

The engine design is for a conventional, non-aerobatic, tractor or pusher configuration with the oil return port in the optimum position. Assuming these points are taken into consideration, the engine will be properly lubricated in all flight profiles. Aircraft that are not conventional (e.g. airships, gyrocopters, dive brake equipped aircraft, etc.) that require engine load at steep inclination angles may have special lubrication requirements.

Select the appropriate connection for the oil return line according to the propeller configuration and oil system layout.

- Position **4, 5** for tractor arrangement
- Position **3** for pusher arrangement

**NOTICE**

Check that the connections for the oil feed and return lines are correct.

**Graphic**

**Connections**

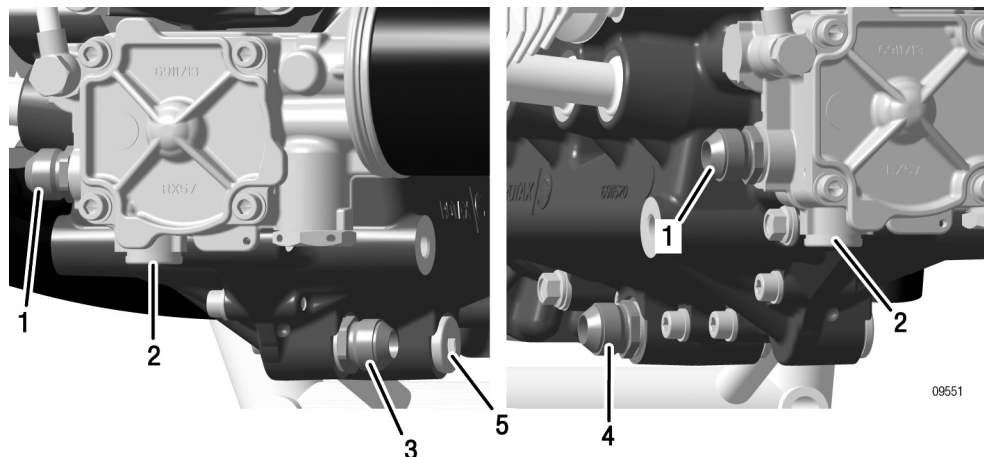

Part	Function
1 or 2	Screw socket (oil feed line) from oil tank or oil cooler
3	Screw socket (oil return line) for pusher arrangement
4 or 5	Screw socket (oil return line) for tractor arrangement

*Fig. 7*

d05398.fm

# BRP-Powertrain

## INSTALLATION MANUAL

### Connections

Screw connection (optional)	
Thread	3/4-16 UNF/M16x1.5
Tightening torque of oil return line	25 Nm (18.44 ft.lb.)

## 2.2) Oil tank

### Connections

See [Fig. 8](#) and [Fig. 9](#).

**NOTICE**

Only use the oil tank provided in the scope of delivery, as its design has changed compared with older tanks.

**NOTE:**

Optional extra:  
Nipple either straight or with 90° elbow. Metric M18x1.5 or UNF 3/4-16 thread.

**NOTICE**

Check what type of thread or connection there is on the supplied oil tank.

### Connections for oil circuit (engine)

### Graphic

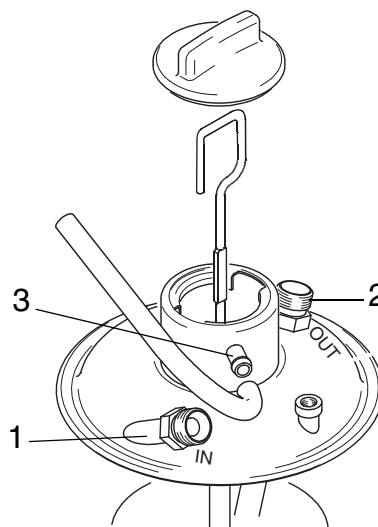

Part	Function
1	Oil feed line
2	Oil outlet
3	Purging nipple

*Fig. 8*

d05398.fm

**BRP-Powertrain**  
INSTALLATION MANUAL

**UNF thread**  
**Optional**

Oil feed line and outlet have UNF threads

<b>Screw connection</b>	
Thread	3/4-16 UNF
Tightening torque of oil feed line and outlet	25 Nm (18.44 ft.lb.)

**NOTICE**

The oil tank cover is also marked with the designations

**IN-** oil return line from crankcase

**OUT-** outlet to oil cooler/oil pump.

**Purging nipple**

<b>Purging nipple</b>	
Outer dia.	8 mm (0.31 in.)
Slip-on length	max. 15 mm (0.59 in.)

**Bent socket 90°**  
**Optional**

part no. 956580

<b>Bent socket 90° / M18x1.5</b>	
Outer dia.	12 mm (0.47 in.)
Slip-on length	max. 24 mm (0.94 in.)
Tightening torque	25 Nm (18.44 ft.lb.)

**Nipple optional**

part no. 956610

<b>Nipple with cap nut / straight</b>	
Outer dia.	12 mm (0.47 in.)
Slip-on length	max. 24 mm (0.94 in.)
Tightening torque	25 Nm (18.44 ft.lb.)

**BRP-Powertrain**  
INSTALLATION MANUAL

Graphic

Oil tank

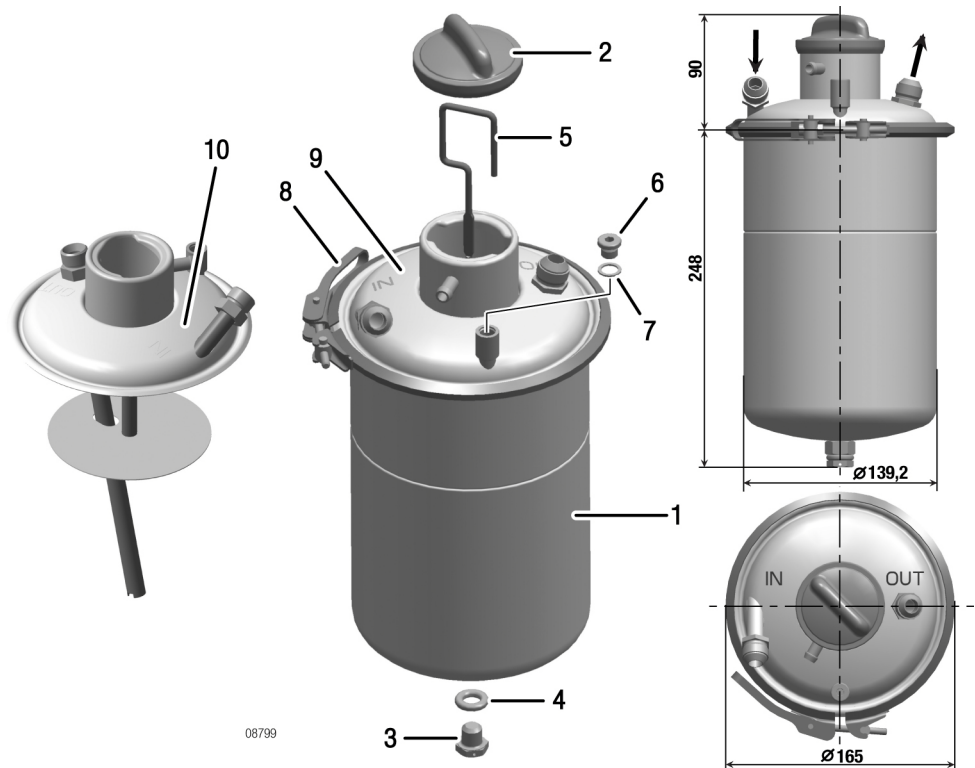

06799

Part	Function
1	Oil tank
2	Bayonet cap
3	M12x12 hex. screw
4	C12x18 gasket ring
5	Oil dipstick
6	M10x1 plug screw
7	A10x14 gasket ring
8	Profile clamp 163
9	Oil tank cover assy. (UNF 3/4-16)
10	Oil tank cover assy. (metric M18x1.5)

*Fig. 9*

**NOTICE**

If the lines are connected incorrectly, the engine will not be lubricated and the engine will be damaged very quickly!

d05398.fm

**BRP-Powertrain**  
INSTALLATION MANUAL

### 2.3) Permissible position and location of the oil tank

**Position and location**

See Fig. 10.

- The longitudinal axis z3 must be parallel to z-axis of the system of coordinates.

Permissible deviation from parallel:  $\pm 10^\circ$

NOTE: This applies to both planes.



Non-compliance can result in serious injuries or death! If the oil tank is located higher, oil might trickle through bearing clearances into the crankcase during longer periods of engine stop. If fitted too low it might damage the oil circuit.

- The oil tank (1) must be positioned on its z-axis such that the normal oil level (2) is always between 0 and -400 mm (-15.75 in.) on the y-axis.

NOTE: If the profile clamp of the oil tank is 360 mm (14.17 in.) below the propeller shaft, then the oil in the oil tank is at the same level as the oil pump. This is the ideal position for the oil tank.

- Install the oil tank free of vibrations and not directly on the engine.
  - Oil tank cover (3) and oil drain screw (4) must be easily accessible.
-



**BRP-Powertrain**  
INSTALLATION MANUAL

Graphic

Position and location of the oil tank

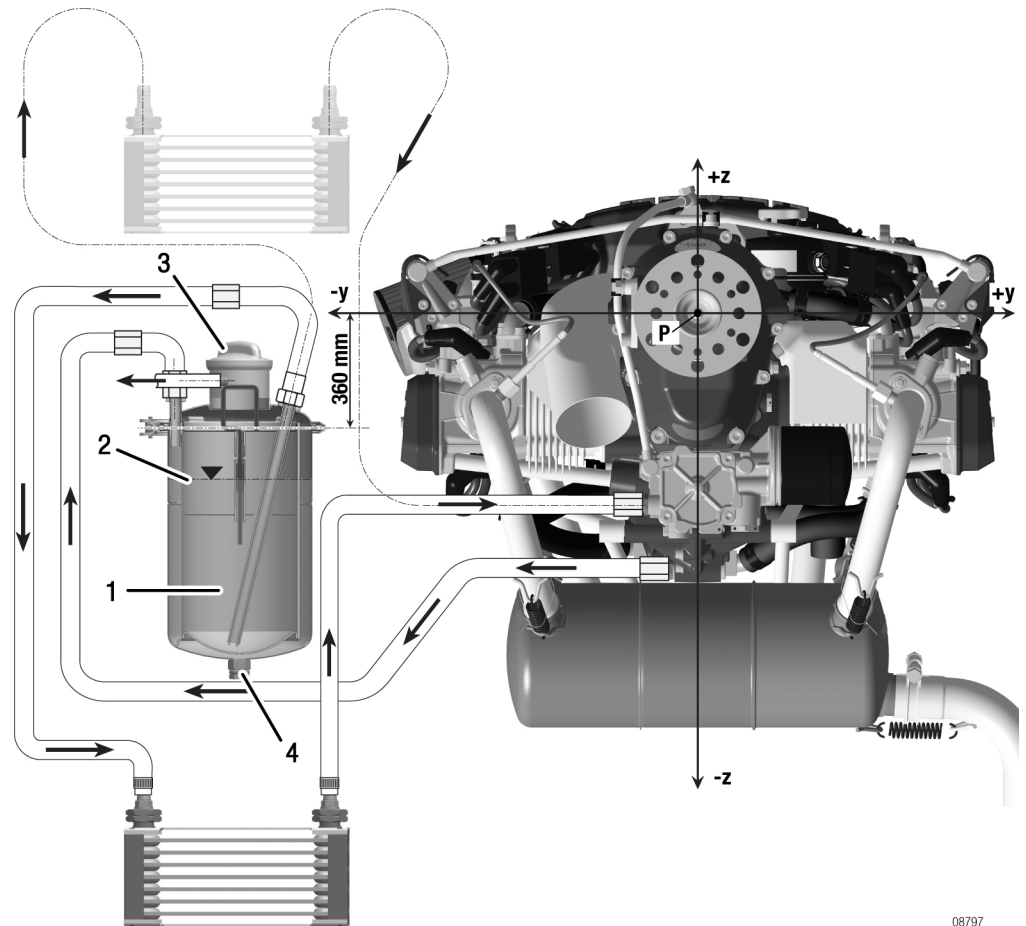

08797

Part	Function
1	Oil tank
2	Oil level
3	Oil tank cover
4	Oil drain screw, hex. screw

*Fig. 10*

d05398.fm

**BRP-Powertrain**  
INSTALLATION MANUAL

NOTES

# BRP-Powertrain

## INSTALLATION MANUAL

### 3) General notes on the oil cooler

**General note** An oil cooler is available for this engine from BRP-Powertrain (see Illustrated Parts Catalog).

**WARNING**

Non-compliance can result in serious injuries or death! Certification according to the latest regulations, such as FAR or EASA, must be conducted by the aircraft or fuselage manufacturer.

**NOTICE**

The oil cooler must be designed to dissipate approx. 10 kW (7.58 BTU/s) of thermal energy at take-off performance.

**NOTICE**

The oil cooler must not restrict oil flow. Test system as per chap. 79-00-00 section 1.3.

**NOTE:** Experience has shown that an oil cooler of at least 160 cm<sup>2</sup> (25 in<sup>2</sup>) is required, provided that air flow is adequate.

---

#### 3.1) Permissible position and location of the oil cooler

**Installation** See Fig. 11.

**WARNING**

Non-compliance can result in serious injuries or death! The oil cooler must be designed and installed such that the permissible operating temperatures are maintained and that these do not exceed or fall below the maximum values. This must also apply to "hot day conditions". If need be, take appropriate measures such as changing the size of the oil cooler, partially covering the cooler, etc.

- The oil cooler should always be installed below the engine oil pump.

**NOTICE**

The oil cooler must be installed with the radiator caps pointing upwards i.e. in positive direction on the z-axis.

**BRP-Powertrain**  
INSTALLATION MANUAL

- If this position is not practical, also install the oil cooler with the radiator caps pointing upwards, i.e. in positive direction on the z-axis.

**NOTICE**

This will prevent unintentional draining of the oil cooler during longer periods of engine stop.

---

### 3.2) Capacity

**Oil tank**

- Capacity without oil cooler and connecting lines min. 3 l (0.8 USgal) depending on the respective installation.

Volume of oil tank	
Up to the MIN. mark	2.5 l (0.66 USgal)
Up to the MAX. mark	3.0 l (0.79 USgal)

- Perform oil level check and add oil if necessary.
-

**BRP-Powertrain**  
INSTALLATION MANUAL

### 3.3) Purging the lubrication system

**Safety**

See Fig. 11.



**WARNING**

Risk of burns and scalds.

Hot engine parts.

Always allow engine to cool down to ambient temperature before starting work.

**Introduction**

Ensure that oil lines are connected correctly and secured and that the oil cooler (if fitted) is in the suction line (1) between the oil tank and the oil pump. Verify that the oil tank is filled up to the maximum level (to the top of the flat portion of the dipstick). Additional oil (up to 0.5 litre (0.13 USgal)) may be added to the tank for the purpose of this procedure.

**Instruction**

The following work procedures must be carried out:

**NOTICE**

Incorrectly connected oil lines to the oil tank or to the engine will result in severe engine damage.

Step	Procedure
1	Disconnect oil return line (2) from the oil tank.
2	Place the free end (3) of the return line into a suitable container (4) below the engine.
3	Plug open connection (5) on oil tank with suitable air tight cap.
4	Remove the spark plug connectors.
5	For easier rotation of engine remove one spark plug from each cylinder. <b>NOTICE</b> Prevent any foreign objects entering through spark plug hole.
6	Using a compressed air line, pressurise the oil tank through its purging connection (6) (on the neck of the tank). Adjust the compressor outlet regulator so that the air line pressure is between 0.4 bar (5.8 psi) and 1 bar (14.5 psi). Do not exceed 1 bar (14.5 psi).



**WARNING**

Non-compliance can result in serious injuries or death!

Do not remove the oil tank cover before ensuring that air pressure has been completely released from the tank.

d05398.fm

**BRP-Powertrain**  
INSTALLATION MANUAL

**NOTE:** The oil tank cover is not pressure-tight, some air can escape.

The pressure in the oil tank has to be maintained during the following steps.

**NOTICE**

The oil tank may empty and as a result introduce air into the oil system. Pay attention to the oil level and fill tank as required.

**NOTICE**

Do not use the starter for this purpose. Fit propeller and use it to turn the engine.

7	Turn the engine by hand in direction of normal rotation until the first pressure indication appears on the oil pressure gauge. Normally this will take approx. 20 turns. Depending on installation it may take up to 60 turns.
8	Stop the pressurisation.
9	Open the cap (5) for the oil return line on the oil tank and reconnect the engine oil return line (2) to the tank. <b>NOTICE</b> Ensure that the suction oil line (1) and oil return lines (2) are connected to the proper fittings on the oil tank. If the oil lines from the engine to the oil tank are incorrectly connected, severe engine damage may result.
10	Refit the spark plug. Restore aircraft to original operating condition.
11	Residual oil may have accumulated in the crankcase. Return it to the oil tank by following the oil level check procedure in the relevant Operators Manual (or SI-912 i-005 Oil level check, current issue).
12	Fill the oil in the tank up to the full mark on the dipstick.

**NOTICE**

Carefully check all lubrication system connections, lines and clamps for leaks and tightness.

**ENVIRONMENTAL NOTE**

Protect their environment. Observe to bury no oil!  
Dispose of oil in an environmentally friendly manner.

a05398.fm

# BRP-Powertrain

## INSTALLATION MANUAL

Graphic

Lubrication system

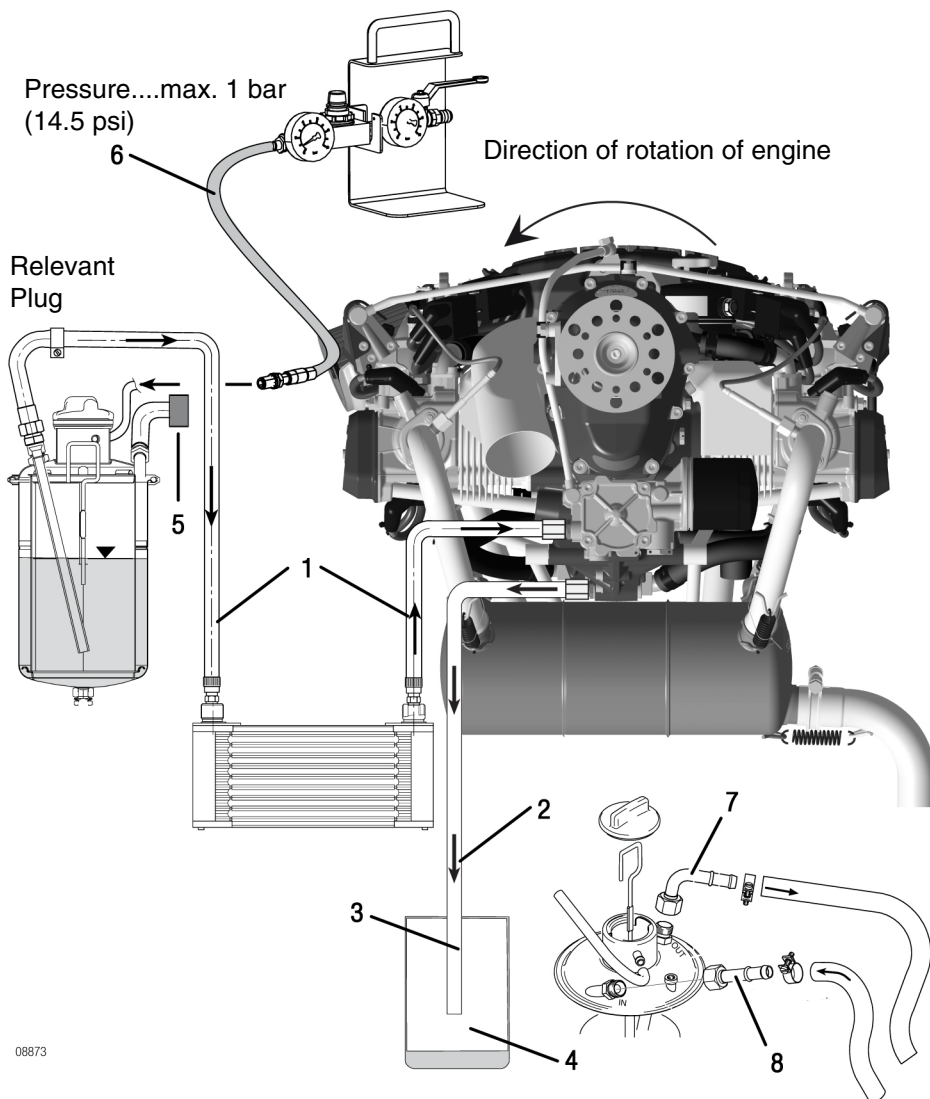

Part	Function
1	Suction line
2	Oil return line
3	Free end
4	Tank
5	Plug
6	Purging connection
7	To oil pump
8	Return from engine

Fig. 11

02233

d05398.fm

**BRP-Powertrain**  
INSTALLATION MANUAL

### 3.4) Checking the hydraulic valve tappet for correct purging

General note See Fig. 12.



Risk of burns and scalds.  
Hot engine parts.  
Always allow engine to cool down to ambient temperature before starting work.

The following check procedure describes the correct method for purging the hydraulic valve tappet.

**Instruction**

The following work procedures must be carried out:

Step	Procedure
1	Remove valve cover on cylinder 1.
2	Turn crankshaft in direction of normal rotation so that cylinder 1 is set to <b>top dead centre</b> ignition (both valves are closed).
3	Push down the rocker arm on the push-rod side with a force (F) of around 70 N (15.74 lb-force) for about 3 seconds. You can use a belt tester, for example, to check approximately how much force is being exerted. Repeat on other rocker arms.
4	Check the size of the gap between the rocker arm and the valve contact surfaces. Max. permitted gap 0.5 mm (0.02 in.). <b>NOTICE</b> If it is possible to push the hydraulic valve tappet further than this limit, an additional engine run for about 5 min. at 3500 rpm, after refitting the valve covers, is required. In order to vent the hydraulic valve tappet, this process can be repeated another 2 times.
5	Repeat on all other cylinders.



**BRP-Powertrain**  
INSTALLATION MANUAL

**Graphic**

Hydraulic valve tappet

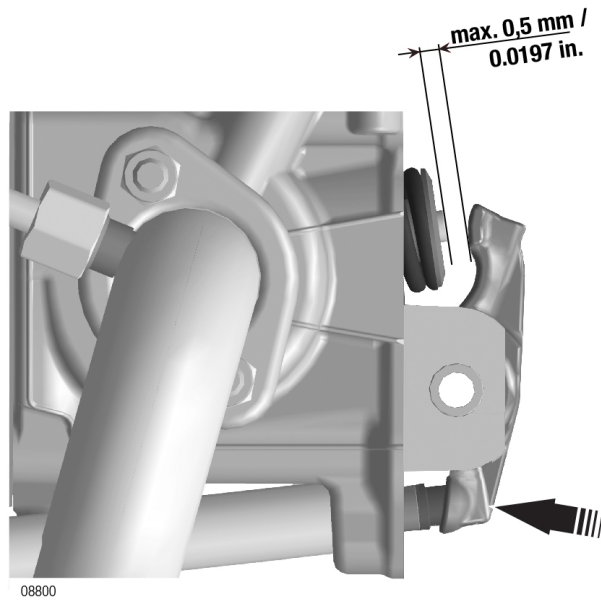

*Fig. 12*

---

### 3.5) Replacement of components

**General note** If an hydraulic valve tappet still malfunctions after several engine runs, it must be replaced and the valve spring support must be inspected for wear.

---

**Work procedures** All work must be performed in accordance with the relevant Maintenance Manual.

---

**BRP-Powertrain**  
INSTALLATION MANUAL

NOTES

## 4) Data for optional components of lubrication system

### 4.1) Oil cooler

**General note** See Fig. 13.

**Weight** See chap. 72-00-00 section: 2.1).

#### 4.1.1) Variants of connectors

**General note** **NOTICE** Counter hold screw sockets when securing the oil lines.

##### UNF screw socket

UNF screw socket	
Thread	3/4-16 UNF
Tightening torque	22 Nm (16.23 ft.lb.) and LOCTITE 648
Tightening torque of oil feed line and outlet	25 Nm (18.44 ft.lb.)

##### Nipple 13.2/9.5

Nipple	
Outer dia.	13.2 mm (0.52 in.)
Slip-on length	max. 21 mm (0.83 in.)
Tightening torque	22 Nm (16.23 ft.lb.) and LOCTITE 243

##### Metric screw sockets

**NOTICE** Counter hold screw sockets when securing the oil lines.

Metric screw sockets	
Thread	M18x1.5
Tightening torque	22 Nm (16.23 ft.lb.) and LOCTITE 648
Tightening torque of oil feed line and outlet, bent socket or hose nipple	25 Nm (18.44 ft.lb.)

**BRP-Powertrain**  
INSTALLATION MANUAL

**Angular tube**

<b>Angular tube (90°)</b>	
Outer dia.	13.2 mm (0.52 in.)
Slip-on length	max. 21 mm (0.83 in.)
Tightening torque	22 Nm (16.23 ft.lb.) and LOCTITE 648

---

**Bent socket**

<b>Bent socket (90°)</b>	
Outer dia.	12 mm (0.47 in.)
Slip-on length	max. 24 mm (0.94 in.)
Tightening torque	25 Nm (18.44 ft.lb.)

---

**Hose nipple with cap nut (straight nipple)**

<b>Hose nipple with cap nut</b>	
Outer dia.	12 mm (0.47 in.)
Slip-on length	max. 24 mm (0.94 in.)
Tightening torque	25 Nm (18.44 ft.lb.)

---

# BRP-Powertrain

## INSTALLATION MANUAL

### Connection variants

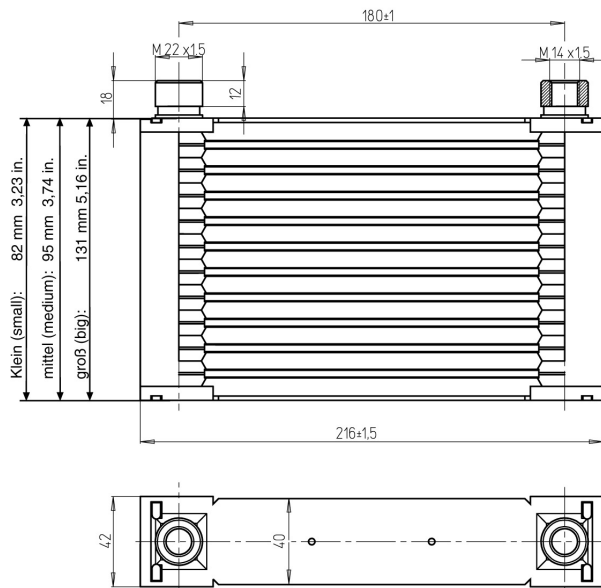
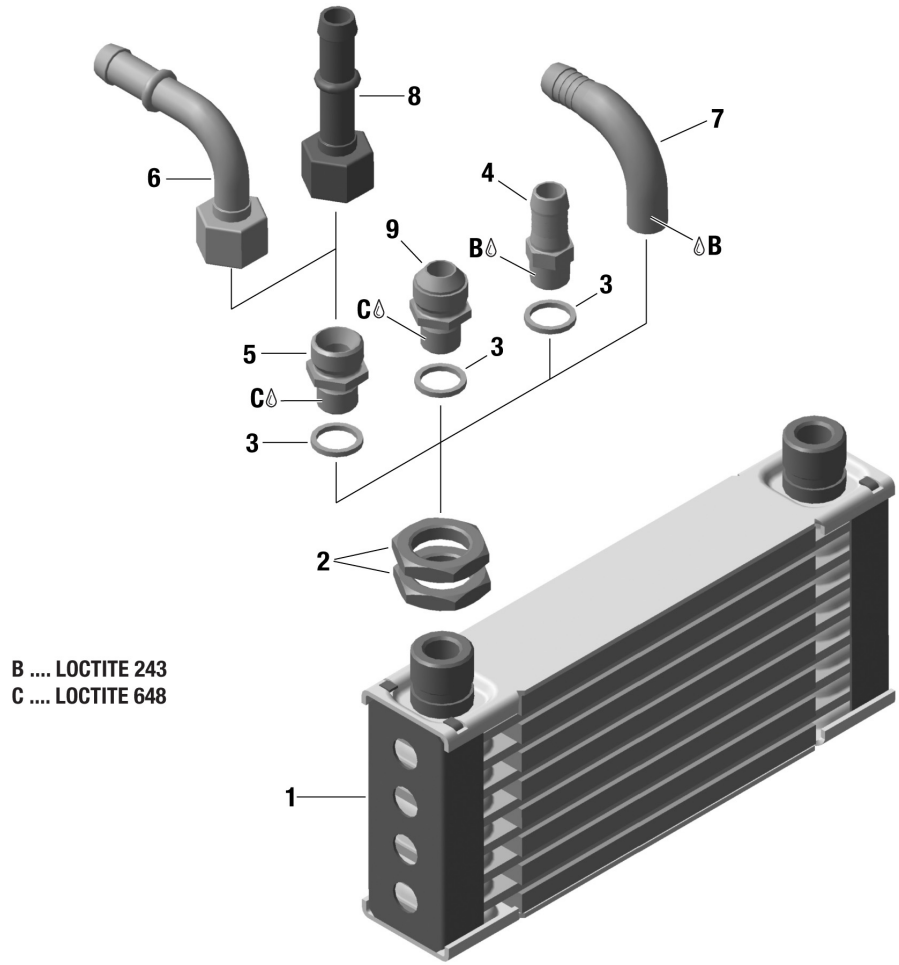

d05398.fm

**BRP-Powertrain**  
INSTALLATION MANUAL

Part	Function
1	Oil cooler
2	M22x1.5 hex. nut
3	Gasket ring 14.2/18/2
4	Nipple 13.2/9.5
5	M18x1.5/M14x1.5 screw socket
6	Bent socket assy.
7	M14x1.5 angular tube
8	Hose nipple with cap nut
9	3/4-16 UNF/M14x1.5 screw socket

*Fig. 13*

08900

**BRP-Powertrain**  
INSTALLATION MANUAL

**Chapter: 80-00-00**  
**ELECTRIC STARTER**

**General note**



Non-compliance can result in serious injuries or death!

When working on the electric starter assy., there is a risk of short circuit and electrical fault.

All installation work on the electric starter assy. must be carried out with engine switched off and the battery (negative terminal) disconnected.

Ignition, main and lane selector switches must be set to OFF.

**Table of contents**

This section of the Installation Manual contains the electric starter of the aircraft engine.

Subject	Page
Electric starter	<a href="#">Page 3</a>
Power supply wires from starter relay to the electric starter	<a href="#">Page 3</a>
Starter relay assy. technical data	<a href="#">Page 4</a>

**BRP-Powertrain**  
INSTALLATION MANUAL

**Overview**

**Electric starter**

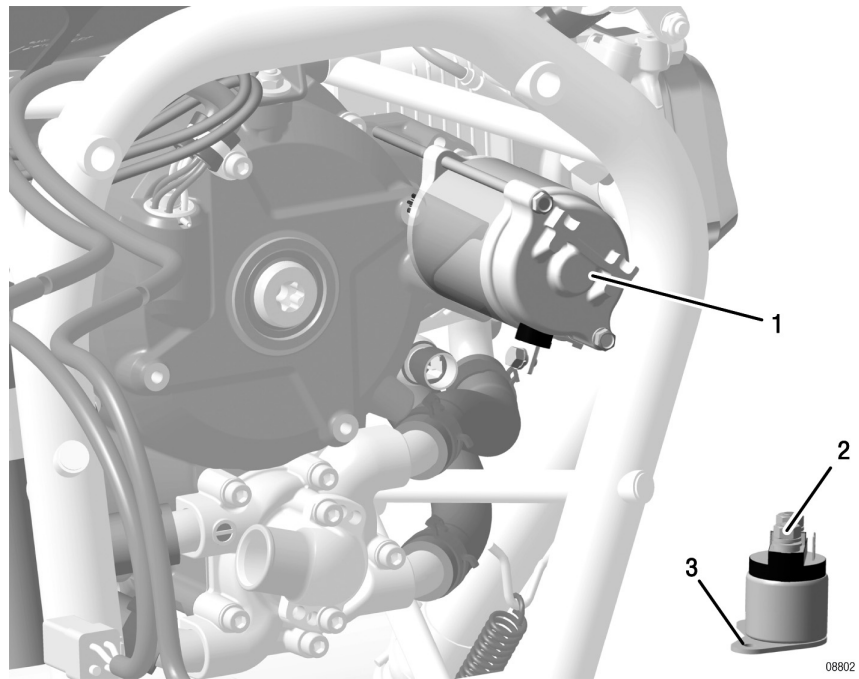

Part	Function
1	Electric starter
2	Starter relay assy.
3	EMS ground

*Fig. 1*



**BRP-Powertrain**  
INSTALLATION MANUAL

## 1) Electric starter

General note

**NOTICE**

Suitable for short starting periods only.

**NOTICE**

Max. 80 °C (176 °F) ambient temperature by the electric starter housing. Activate starter for max. 10 sec. (without interruption), followed by a cooling period of 2 minutes.

### 1.1) Power supply wires from starter relay to the electric starter

**Cross section** At least 16 mm<sup>2</sup> (2.48 in<sup>2</sup>)

**Output** 0.8 kW (0.9 kW optional)

**Connection** See [Fig. 2](#).  
Positive terminal (2): M6 screw connection (tightening torque 4 Nm (36 in.lb)) suitable for cable terminals according to DIN 46225 (MIL-T7928; PIDG or equivalent).

**Graphic** Connection

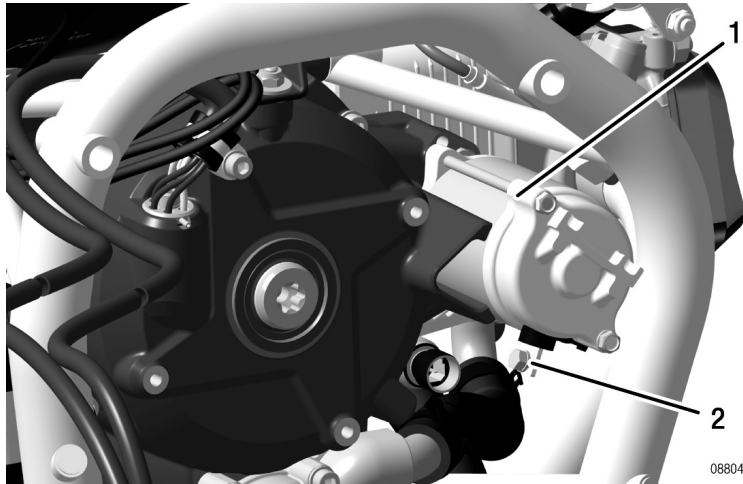

Part	Function
1	Electric starter
2	Positive terminal

*Fig. 2*

d05175.fm

**Grounding cable** Grounding cable via engine block.

**BRP-Powertrain**  
INSTALLATION MANUAL

## 1.2) Starter relay assy. technical data

<b>General note</b>	See Fig. 3.  <b>NOTICE</b> Activation of starter relay limited to short duration. The duty cycle over an interval of 4 minutes is 25%.
<b>Nominal voltage</b>	- 12 V/DC
<b>Control voltage</b>	- Min. 6 V - Max. 18 V
<b>Switching current</b>	- Max. 75 A 8 (permanent) - Max. 300 A/1 sec. (short duration)
<b>Temperature</b>	Permissible ambient temperature: - Min. -40 °C (-40 °F) - Max. +100 °C (212 °F)
<b>Weight</b>	See chap. 72-00-00 section: 2.1).
<b>Connections</b>	<b>Main current connections (1):</b> M6 screw connection (tightening torque 4 Nm (36 in.lb.)) suitable for cable terminals according to DIN 46225 (MIL-T-7928; PIDG or equivalent). <b>Control wiring (2):</b> 6.3x0.8 plug connector suitable for Faston connector (female) according to DIN 46247 (MIL-T-7928; (PIDG) or equivalent).
<b>Grounding</b>	<b>NOTICE</b> The starter relay must be isolated from the aircraft ground. See chap. 24-00-00 section: FUSE BOX connections.

**BRP-Powertrain**  
INSTALLATION MANUAL

Graphic

Starter relay

NOTE:

Starter relay must be installed isolated from airframe ground.

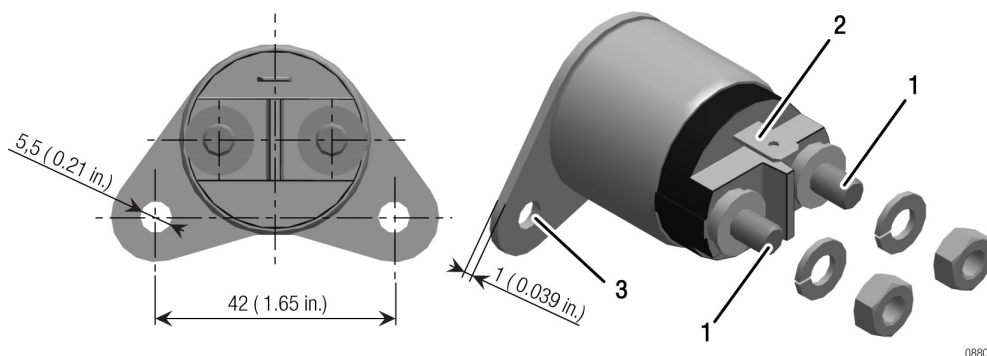

Part	Function
1	Main current connections
2	Control wiring
3	Ground

*Fig. 3*

d05175.fm

**BRP-Powertrain**  
INSTALLATION MANUAL

NOTES

d05175.fm





---

Motornummer / Engine serial no.

---

Flugzeugtype / Type of aircraft

---

Flugzeugkennzeichen / Aircraft registration no.

ROTAX® Vertriebspartner

ROTAX® authorized distributor

[WWW.FLYROTAX.COM](http://WWW.FLYROTAX.COM)